



The image shows a large, industrial-grade grey machine, the QX-300 Flex, used for packaging. A large roll of white material is being processed by the machine. Below the roll, two trays containing red granules are visible. The machine has several control buttons and a small screen on its front panel.

# QX-300 Flex

**Best quality packing, excellent value**

Innovation  
Commitment Knowledge  
Experience Quality  
Precision Performance

**Ishida Europe: understanding and tackling the weighing and packing line challenges you face**

- Unique engineering expertise, combined with practical industry knowledge in your sector
- Global applications experience, including snacks, meat, poultry, ready meals, fresh produce, dry and frozen foods, bakery, confectionery, pasta and non-food applications
- R&D resources and commitment to support both continuous improvement and major innovation
- Solutions include consultancy and project management, complete packing lines, multihead weighers, traysealers, seal testers, X-Ray and vision inspection systems, snack food bagmakers, checkweighers, traysealers, weigh-batchers and pick-and-place systems.

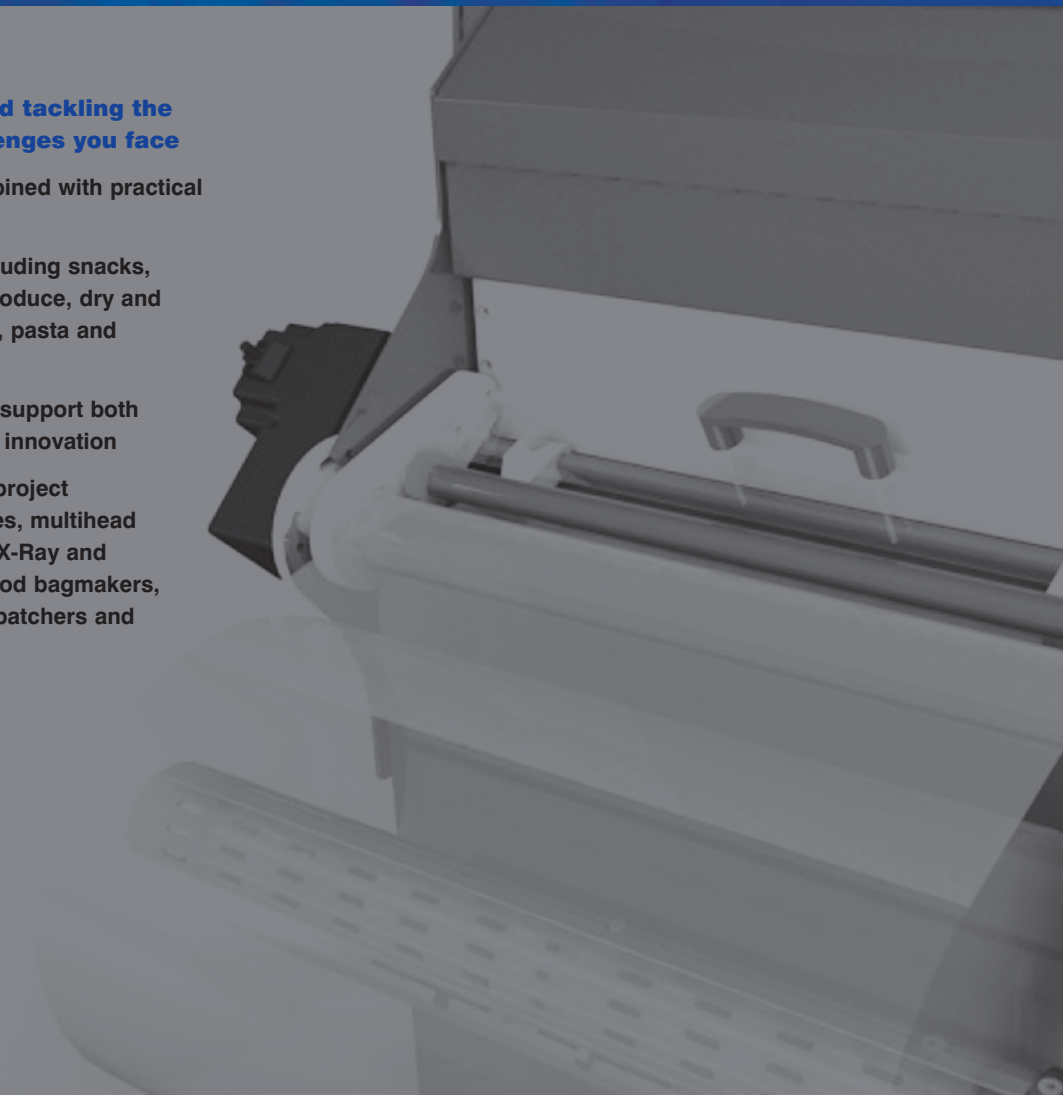

# QX-300 Flex



## Semi automatic traysealer

**The QX-300 Flex is based on tried and tested technology which caters for the needs of the exciting, fast growing top seal tray market, combining excellent seal integrity and pack presentation with flexibility, quick changeovers and user-friendly operation in a compact and hygienic design.**

The QX-300 is the ideal solution for growing businesses that want to start offering their products in top sealed trays. It is also highly suitable for use as an R&D machine, keeping product development costs low whilst reducing the impact of increased cost developing new products on existing fully automatic lines.

In brief, the QX-300 is a highly reliable, hygienic and easy to operate machine that offers an excellent return on your investment.

The QX-300 will give the same performance and pack appearance as it's bigger QX Flex family members, the compact QX775 and the Flagship QX1100 range of traysealers.



### Quality and reliability

High sealing pressure combined with precise control of sealing time and temperature offer the highest seal integrity for optimum shelf-life and perfect pack presentation.

Durable, stainless steel construction combined with high quality components ensures reliable operation, thus maximizing production availability.

The QX300 Flex's simple design allows easy access for operation, cleaning and maintenance.

### Compact and flexible

The compact construction of the machine reduces the floor space required whilst roller castors are fitted as standard to give maximum flexibility when moving around in the factory. This makes the QX-300 the perfect solution for any company where space is a premium.

### Sealing tool solutions

Each sealing tool can be designed to suit any application and offers the highest quality pack presentation to suit demanding market requirements. Tools can be supplied for outside cut, Skinpack and shrink film applications.

### Rapid changeover

The machine is designed with quick and easy changeovers in mind. Operators can easily change films and sealing tools using the quick release features. Particularly useful and efficient for ready meal applications where the customer's product range and production volumes fluctuate.

### Easy operation and set up

The simple control allows the operator to easily select sealing modes to suit any application. Sealing time and temperature is accessible from the HMI (Human Machine Interface) along with vacuum and gas settings.

### MAP

Modified atmosphere is a simple case of connecting pre mixed gas or a gas mixer to the machine. The optional gas mixer can be easily adjusted to suit any product type.

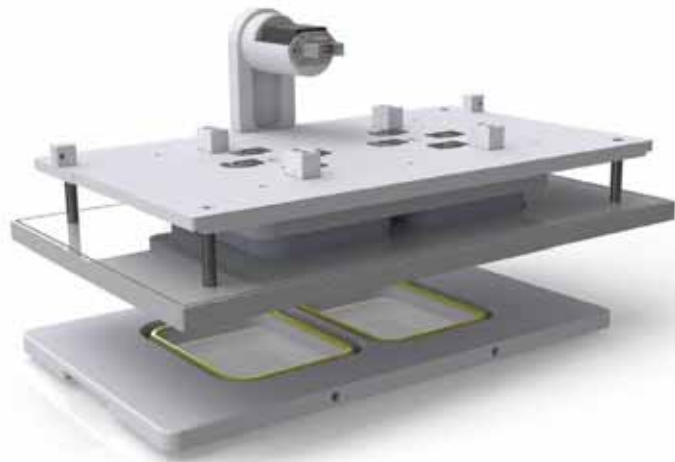

- QX300 Flex menu
- Sealing temperature
- Seal time
- Seal only
- Vacuum only
- Vacuum and gas
- Gas flushing
- Skinpack



## Technical Specifications

### Tray size chart and formats

	143	143	143		215	215
162						
162						
	143	143	143			
315						
	215	215			430	
315						

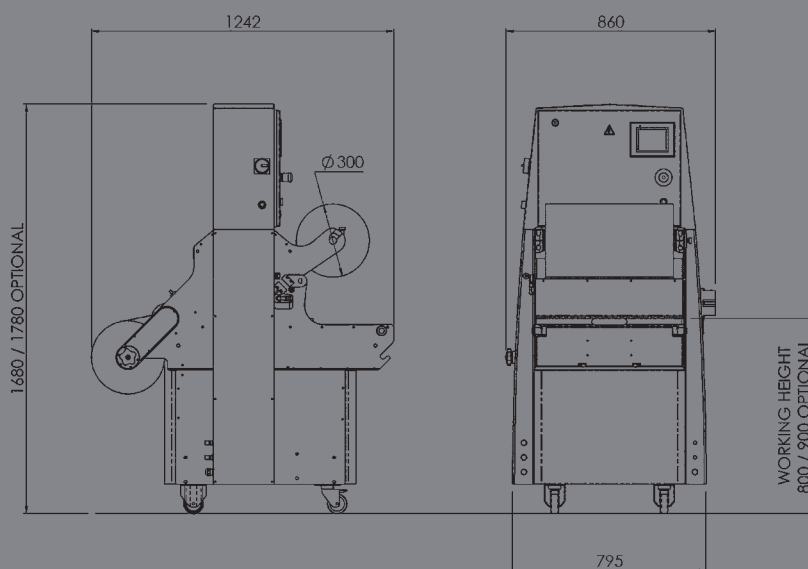

Specifications	
Minimum Tray Size	95 x 95mm
Tool formats	<ul style="list-style-type: none"> <li>• Seal Only and MAP</li> <li>• Skinpack</li> </ul>
Type of film cut	Outside cut with 2-5mm overhang for laminate and shrink films
Maximum tray height	130mm
Number of impressions per tool	From 1 to 6
Maximum cycle speed	8 Cycles per minute
Maximum film reel diameter	300mm
Machine weight	350 kg
Supply Voltage (integrated transformer for 200V)	200/415V 3 Phase+N+E, 25 KVA
Air supply	25nL/MIN @ 7 bar

## Working with you every step of the way

Our extensive R&D investment is directed at meeting the challenges of the fast-changing food industry around the globe.

We aim to support our partners fully, from the very start of the buying process, and you will find many equipment brochures, visual animations and case studies available on our website. When you are ready to make contact, a well-resourced network of Ishida companies, distributors and agents, extending across Europe, the Middle East and Africa, can provide advice and organise demonstrations and trials.

Installation is rapid and efficient. For integrated packing lines, we use proven project management techniques and methodologies, tuned to your key objectives and specifications.

A dedicated pan-European service engineering team helps to maximise the performance, functionality and reliability of our installed base. In addition, spares facilities are strategically placed throughout the territory, offering 24-hour delivery in most cases.



helpline • spares • service • training

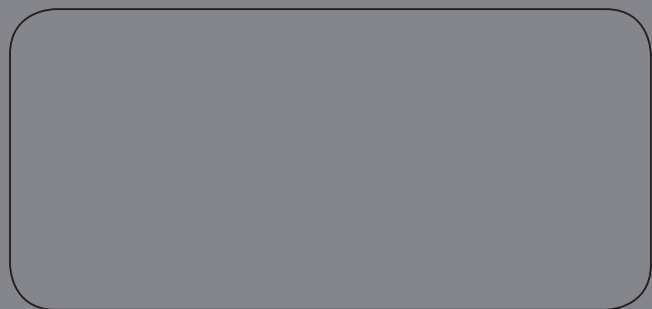

**Ishida Europe Limited**  
11 Kettles Wood Drive  
Woodgate Business Park  
Birmingham  
B32 3DB  
United Kingdom  
Tel: +44 (0)121 607 7700  
Fax: +44 (0)121 607 7666  
info@ishidaeurope.com

**Ishida Czech Republic**  
Tel: +420 317 844 059  
Fax: +420 317 844 052  
info@ishidaeurope.cz

**Ishida Romania**  
Tel: +40 (0)21 589 73 52  
Fax: +40 (0)21 310 34 22  
info@ishidaeurope.ro

**Ishida France**  
Tel: +33 (0)1 48 63 83 83  
Fax: +33 (0)1 48 63 24 29  
info@ishidaeurope.fr

**Ishida Russia and CIS**  
Tel: +7 499 272 05 36  
Fax: +7 499 272 05 37  
info@ishidaeurope.ru

**Ishida Germany**  
Tel: +49 (0)791 945 160  
Fax: +49 (0)791 945 1699  
info@ishida.de

**Ishida South Africa**  
Tel: +27 (0)11 976 2010  
Fax: +27 (0)11 976 2012  
info@ishida.co.za

**Ishida Middle East**  
Tel: +971 (0)4 299 1933  
Fax: +971 (0)4 299 1955  
ishida@ishida.ae

**Ishida Switzerland**  
Tel: +41 (0)41 799 7999  
Fax: +41 (0)41 790 3927  
info@ishida.ch

**Ishida Netherlands**  
Tel: +31 (0)499 39 3675  
Fax: +31 (0)499 39 1887  
info@ishida.nl