

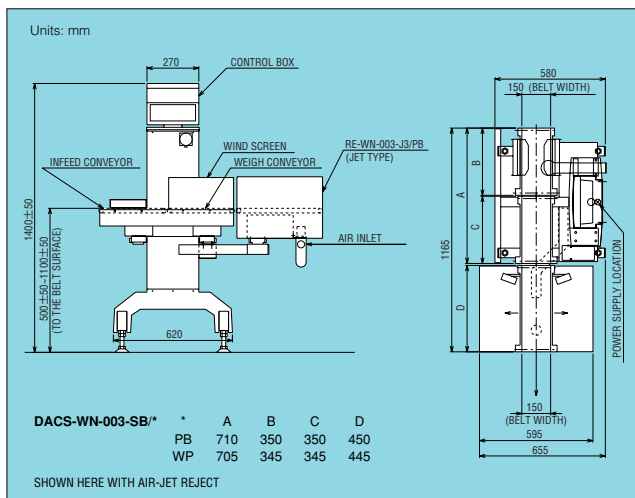

This new state-of-the-art checkweigher combines versatility and flexibility with even greater accuracy and higher speeds. The DACS-WN-003 combines user-friendly operation with unequalled performance for products up to 300g and can achieve a maximum speed of 330 packs per minute. The Remote Control Unit (RCU) features a high visibility fluorescent graphic display with tactile membrane keyboard which can be angled to suit individual applications. The advanced Host Computer Interface concept enables the checkweigher to become part of a fully-integrated production and packaging line, providing detailed production and weighing information to support total factory control. Available in both painted body and waterproof specification.

## DIMENSIONS



## SPECIFICATIONS

Model	DACS-WN-003
Weighing Range	3g ~ 300g
Weighing Speed (Max) (*)	330 WPM
Weighing Accuracy (*) <small>(Figure in brackets refers to waterproof version)</small>	±0.2 g (±0.7 g)
Minimum Graduation	0.1g
Remote Control Unit (RCU)	Fluorescent Graphic Display
Weigh Cell	Newly designed double-beam strain gauge loadcell
Weigh Conveyors (mm) <small>(Figure in brackets refers to waterproof version)</small>	350 (345) (L) × 165 (160) (W) 450 (445) (L) × 165 (160) (W)
Reject Conveyors (mm) <small>(Figure in brackets refers to waterproof version)</small>	350 (345) (L) × 165 (160) (W) (air-jet & arm-type) 450 (445) (L) × 165 (160) (W) (air-jet & arm-type)
Height Adjustment of Conveyors (mm)	500±50 ~ 1100±50
Belt Width	150mm
Product Dimensions	L: 30 ~ 410 mm W: 30 ~ 150 mm H: 10 ~ 130 mm
Zero Adjustment	Continuous automatic dynamic compensation
Number of Presets	100
Structure of Waterproof Machines	IP 65 Approval
Printer	Optional

Note: Specification subject to change without notice. (\*) Varies according to product shape and condition.





# DACS-WN SERIES

The new modular cantilevered construction of the DACS-WN checkweigher includes a host of innovative, easy to operate features, offering new levels of flexibility, hygiene, speed and accuracy.

## NEW FEATURES

The DACS-WN Series offers a number of newly-developed Ishida innovations:

### ● New Loadcell

A new Ishida developed high-speed loadcell improves sensitivity, response and accuracy.

### ● New Drive Units and Weigh Conveyor

The light weigh conveyor, enhanced direct drive motor and a unique low friction belt, combine to make the DACS-WN the fastest and most accurate in its class.

### ● Wide Selection of Belts

For maximum flexibility, a wide range of belt sizes is available to suit the size of individual products, optimizing pack-handling

and product throughput.

### ● Modular Design

The modular, Pedestal Tower construction of the main body permits easy, on-site height adjustment of the belt conveyors.

The layout of the electronics on a single-layered panel within the vertical tower makes the machine design unique and offers remarkable accessibility for maintenance. This reduces downtime to a minimum.



Remote Control Unit (RCU) and Printer.

### ● Host Interface (optional)

The checkweigher can be interfaced via a 'DDE' link to many Windows® packages such as Excel® for integration into the end-user's management and control systems.

## PROVEN TECHNOLOGY

### ● Anti-Floor Vibration Mechanism (AFV)

Compensates for external vibration detected by use of a separate loadcell. Maintains maximum accuracy, even on a vibration-intensive installation site.

### ● Digital Filtering

Permits automatic setting of the filter characteristics to weighing conditions resulting in enhanced checkweigher speed and accuracy.

### ● Digital Signal Processor (DSP)

In order to handle the many high-speed adding and multiplying computations required for digital filtering, AFV compensation and weigh data processing, a high speed 'DSP' chip has been included. The DSP permits accurate signal processing under a wide range of weighing conditions.

## BENEFITS

### ● Easy to Clean

The robust cantilever construction and quick-release conveyors make cleaning of the machine, and the floor space underneath, extremely simple. Cleaning can be done in a matter of minutes, reducing downtime to a minimum.

### ● Expanded Presets

100 preset memories are now available for easy set-up parameters.

### ● Choice of Reject Systems

A comprehensive selection of reject systems is available including:-

- Arm Rejects
- Air Rejects
- Drop Belt Rejects

### ● Graphic Display

Histograms, bar-graphs, X-bar charts, speed and recent pack weights can be displayed on an easy-to-read fluorescent graphic screen for continuous monitoring of production data.

Ishida, the world leader in weighing technologies, also manufactures a full line of multihead weighers.



**ISHIDA CO., LTD.**

44 SANNO-CHO, SHOGOIN, SAKYO-KU  
KYOTO, 606-8392 JAPAN  
PHONE : 81-75-771-4141  
FACSIMILE: 81-75-751-1634  
URL: <http://www.ishidajapan.com>

**HEAT AND CONTROL**

**HEAT AND CONTROL, INC.**

21121 CABOT BLVD.  
HAYWARD, CA 94545-1132 USA  
PHONE: 1(800)227-5980  
1(510)259-0500  
FACSIMILE: 1(510)259-0600  
[www.heatandcontrol.com](http://www.heatandcontrol.com)  
[info@heatandcontrol.com](mailto:info@heatandcontrol.com)