

**HEAT AND CONTROL**

®

## Mastermatic® Snack Food Fryer



*Standard fryers are available with 12 to 65 sq. ft. (1.1 to 6 sq. meters) of frying area.*

### Automated continuous frying for a variety of snack food products.

#### Precise frying control

Accurately control temperature and conveyor speed for consistently uniform products including:

Tortilla chips	Soy & wheat nuts	Corn chips
Cheese balls	Pasta snacks	Pork rinds
Pellet snacks	Vegetable snacks	Noodles

#### Superior quality products

Low oil volume provides fast oil turnover rates for fresh, crisp products with a longer shelf life. Unique Mastermatic Cool Zone™ extends oil life.

#### Easy installation

All models are pre-wired and include operating controls. Fryer systems can be delivered pre-piped to reduce the cost of installation.

#### Maximum versatility

A variety of conveyor belts are available for different products. All models feature multiple heating zones for optimal temperature control.

#### Minimal floor space

Mastermatic fryers provide a large frying area from a relatively small footprint.

#### Easy cleaning

Main and submerger conveyors separate and raise clear of the pan to facilitate cleaning. Fryer can be built to USDA standards for meat snacks.

#### Optional features

- Continuous oil filter
- Sediment removal conveyor
- Automatic oil level control
- Inspection equipment
- Packaging systems

# Mastermatic® Snack Food Fryer

Model MSFF

Choose from our standard conveyor designs or let us custom design a fryer for your unique snacks.

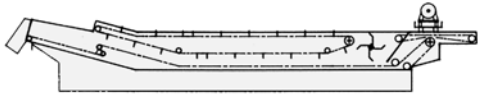

**Buoyant product**

*Drop-in product feed. Corn and tortilla chips, cheese balls, puff pellet snacks, noodles, french fries, pasta.*



**Free-flowing product**

*Nuts, sunflower seeds, soy and wheat nuts, pellet snacks, vegetable snacks, beans, pasta snacks.*

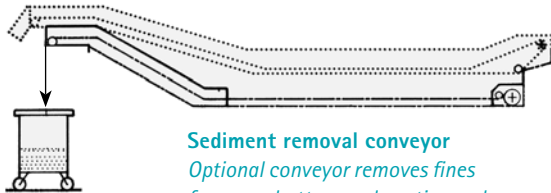

**Sediment removal conveyor**

*Optional conveyor removes fines from pan bottom and continuously deposits them into an external container. Note: Adds approximately 5 feet (1.53m) to fryer length.*

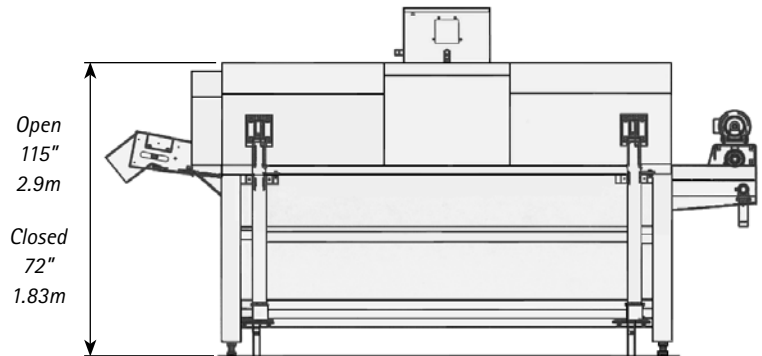

Standard Model Examples	Heating Zones	Overall Length feet/meters	Overall Width inches/mm
8-24	2	11' / 3.36	60" / 1524
10-24	2	13' / 3.97	60" / 1524
8-30	2	11' / 3.36	66" / 1676
28-30	3	31' / 9.46	66" / 1676
8-36	2	11' / 3.36	72" / 1829
36-36	3	39' / 11.90	72" / 1829
8-42	2	11' / 11.36	78" / 1981
32-42	3	35' / 10.68	78" / 1981

*Fryer lengths are available in 2' (.6m) increments up to 36' (11m) long with useable belt widths up to 40" (1016mm). Dimensions are rounded to the nearest inch / millimeter / meter.*

Constant improvement and engineering innovations mean these specifications may change without notice.



**HEAT AND CONTROL**

