

Metermaster Salt Applicator



Dispense powdered and granulated salt over product on a moving belt with consistent and repeatable accuracy.

Metermaster evenly applies topical salt coatings without caking and clogging. A simple reciprocating distribution bar uniformly meters salt onto product passing beneath it. Metermaster requires no readjustment after cleaning, so coverage remains uniform from one production run to the next.

Reliable and simple, Metermaster has no brushes, rollers, or other rotating mechanisms. "Tools-free" construction makes the applicator reliable, and simple to operate and clean.

Standard Features

- 316 stainless steel all-welded construction
- Removable filter screen
- "Tools-free" product changeovers
- Variable speed motor with digital readout

Options

- Custom sizes to fit most conveyor widths
- Heated hopper and custom hopper designs
- Salt level sensors
- Portable stand with casters
- NEMA 4 stainless steel control console
- High-temperature unit (over 150°F)

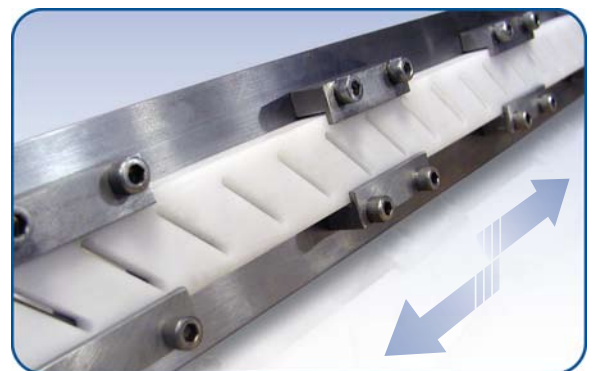

Reciprocating distribution bar evenly meters salt without clogging.

Metermaster Salt Applicator

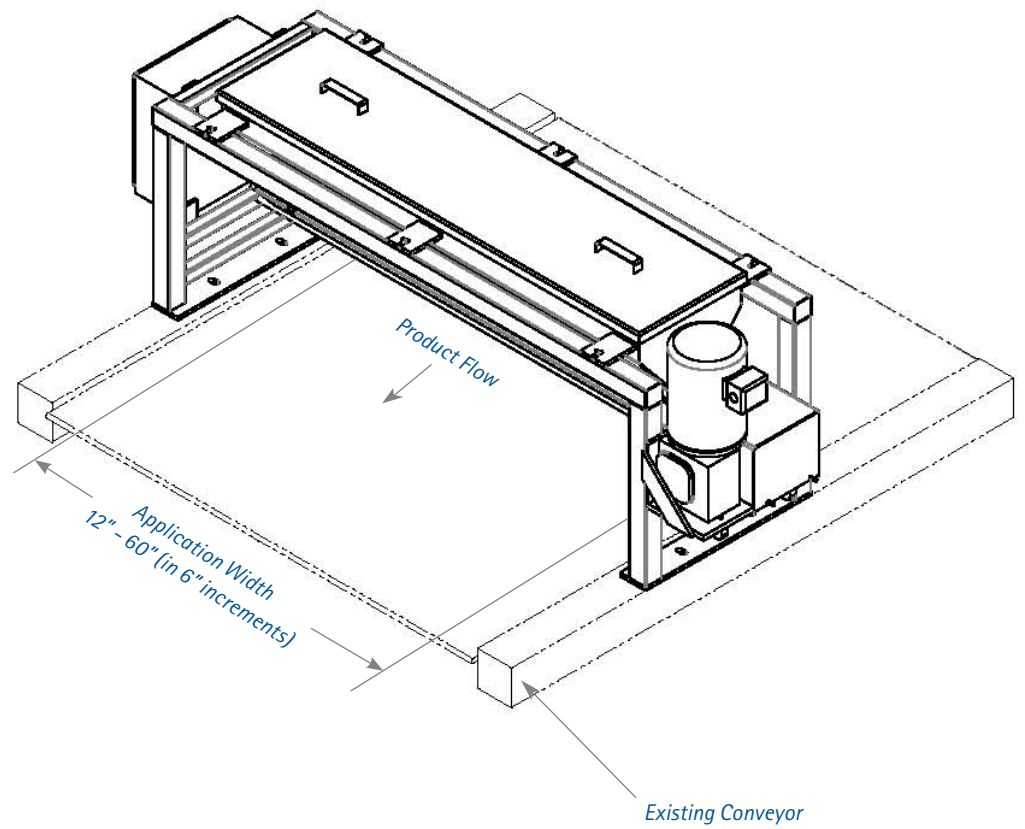

Utilities

- 1.8 amp at 110V, 1ph, 60Hz

Constant improvement and engineering innovations mean these specifications may change without notice.

