

HEAT AND CONTROL

MasterTherm™ Snack Fryer



MasterTherm™ Snack Fryer

Unique thermal fluid heated design delivers uniform cooking and simple cleaning.

Fry a variety of snacks uniformly, evenly, and efficiently. MasterTherm cooks each piece of product at the same temperature for consistently uniform color and texture. Its unique design evenly heats cooking oil, improves durability, and simplifies sanitation.

Uniform oil heating

- U-tube heat exchanger uniformly heats oil throughout the fryer so product is cooked equally and with even color.
- Cooking oil moves freely between heating tubes, promoting uniform heat transfer across the width and length of the fryer.
- Uniform heating eliminates oil currents that force product to one side of the fryer, preventing coating damage and uneven product transfer.
- Thermal fluid volume is minimal. It circulates rapidly so cooking oil temperature adjusts quickly to changes in product load.

Simple sanitation

- Generous spacing between heating tubes facilitates cleaning and eliminates areas where lines can hide.
- Elevated design provides access for cleaning beneath the fryer.

Reliable operation

- Heat exchanger tubes move independently to prevent thermal stress damage.
- Heavy-duty construction for high-volume continuous production.

Range of sizes

- Fry lengths are available from 10 to 32 feet in 2 foot increments (3 to 9.8 meters in 0.6 meter increments).
- Conveyor widths in 28", 30", 36" and 42" (71, 76, 91, and 107 cm).
- Custom sizes are available for special applications.

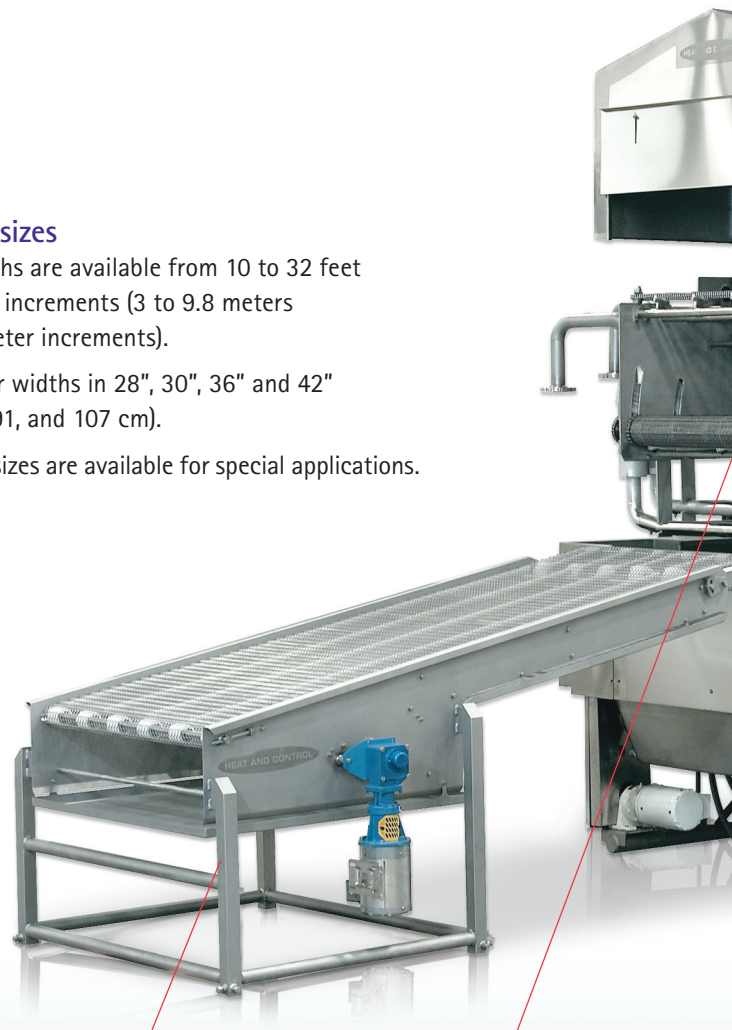

Product feed and transfer conveyors are available to fit your line.

Adjust the fryer infeed conveyor to handle different products.

MasterTherm uniformly fries a wide range of nuts, corn chips, pellets, extruded snacks, and bakery products.



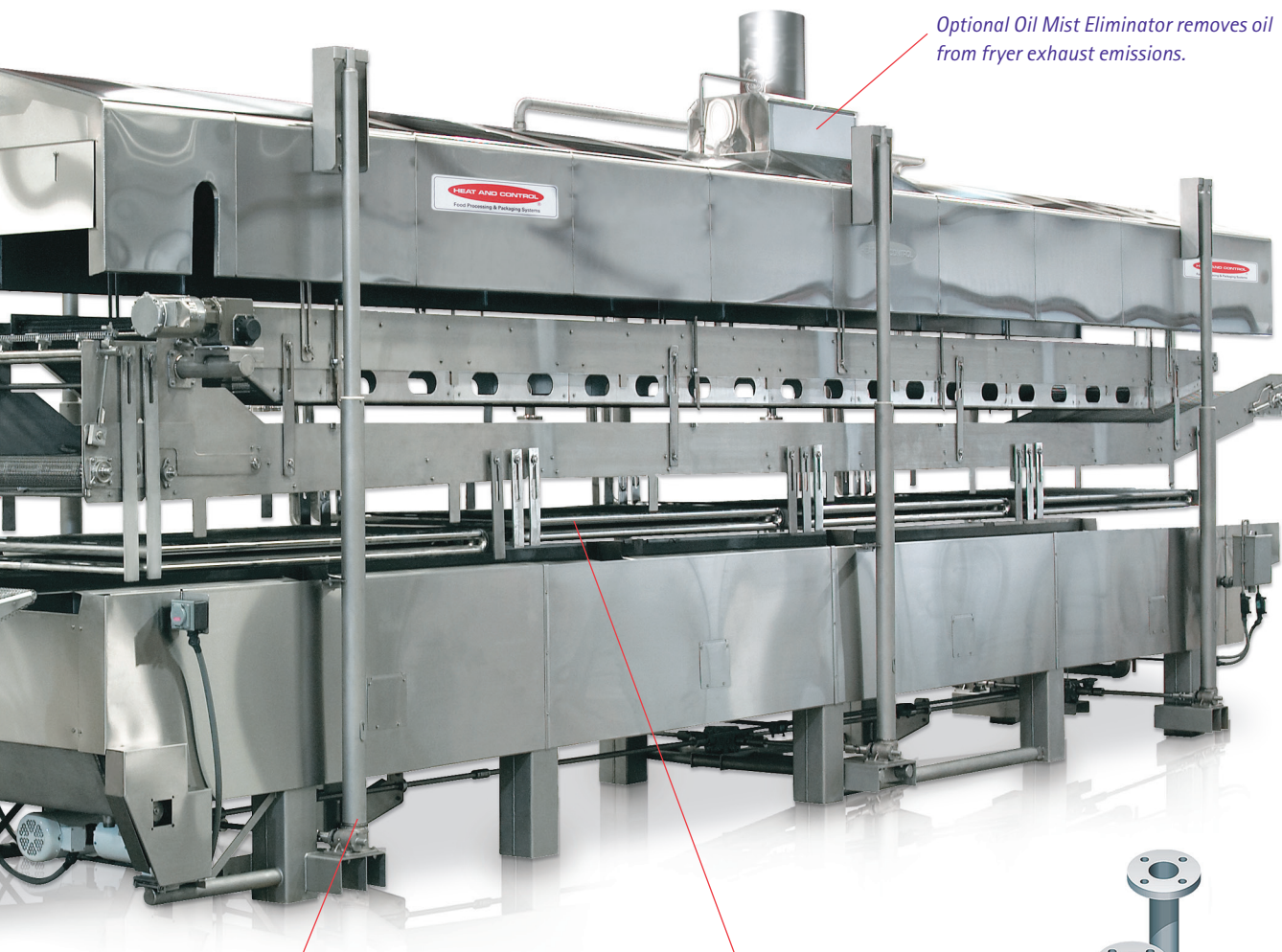

Optional Oil Mist Eliminator removes oil from fryer exhaust emissions.

Hoist system safely raises the hood and conveyors.

MasterTherm Heat Exchanger

Unique U-tube design uniformly heats cooking oil, uses minimal thermal fluid and improves durability.

Open spacing between tubes eliminates areas where fines accumulate and cause overheating and sanitation problems.

Tubes move independently to prevent stress damage.

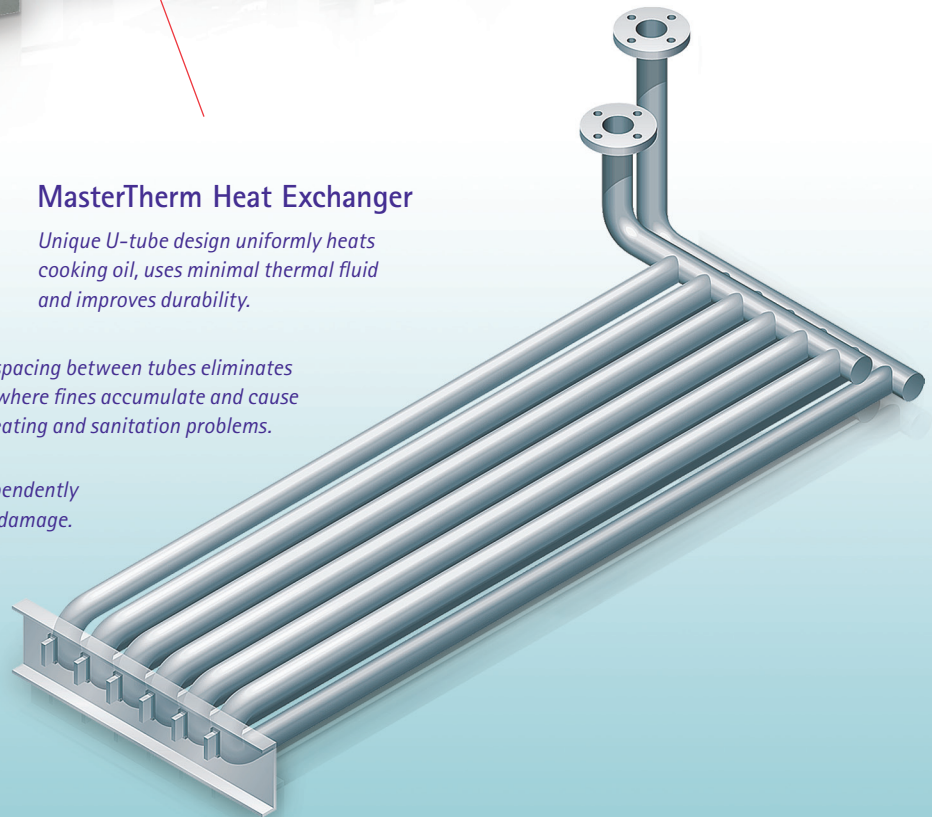

MasterTherm™ Snack Fryer

Model MTF

Customize your MasterTherm using a variety of conveyors and accessories.

MasterTherm Options

- Multiple temperature zones for custom cooking profiles
- Continuous fines removal for products that generate excessive fines
- Oil Mist Eliminator removes oil from stack emissions
- Stack heat recovery system utilizes heat for sanitation and other uses
- Automatic oil level control system
- PLC control system

The fryer experts since 1950, Heat and Control builds a variety of fryer designs and sizes. Contact us today for the ideal fryer for your products!



With a variety of conveyor options, MasterTherm is the ideal fryer for many types of foods.

Fragile semi-buoyant product

Meat patties, eggrolls, vegetables, clams, eggplant, fish

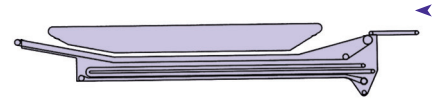

Non-buoyant product

Meatballs, bone-in chicken, deli loaves

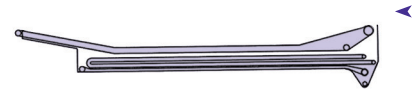

Tempura coated product

Fish and chicken nuggets, shrimp, potato pancakes, pocket products



Sediment removal conveyor options

Remove fines from pan bottom and continuously deposit them into the main oil outlet or into a discharge waste container

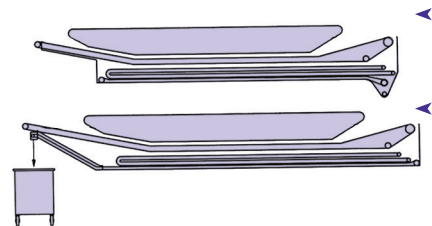

Constant improvement and engineering innovations mean these specifications may change without notice.

HEAT AND CONTROL

