

HEAT AND CONTROL[®]

SureCoat[®] Batter Applicator



HEAT AND CONTROL

®

SureCoat[®] Batter Applicator

Uniformly apply batters and marinades to all surfaces of formed and natural products.

One applicator for all coatings

Easily switch from a submerger applicator to an optional multi-curtain batterfall unit. Special designs are available for thick batters and coatings.

Total coverage

All surfaces and cavities are thoroughly coated, even underneath the product.

Continuous filtration

Double basket filters continuously protect the product and pump.

Minimal batter carryover

A unique belt wiper and air knife keep excess batter in the applicator.

Quick and easy cleaning

Tilt the conveyor up for complete cleaning access. Parts remain on the applicator during cleaning.

Built to USDA standards

All-welded construction facilitates sanitation and improves durability.

Conveyor options

Lay-on, infeed and transfer conveyors are available to suit your production needs.

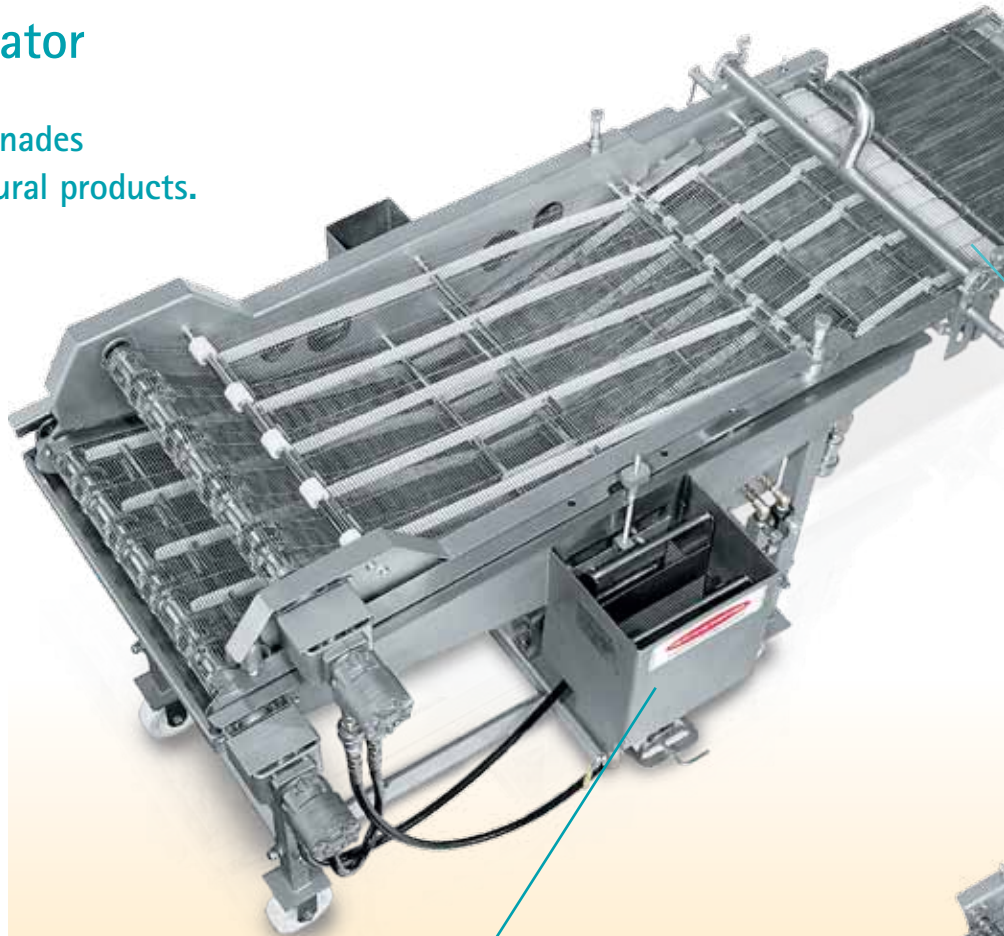

*Easily adjust batter level in the tank.
Clean one filter basket while the second
basket protects product and pump.*



Tilt-up conveyors allow complete internal access for cleaning.



Two or four curtain batterfall option assures uniform coverage of formed products, vegetables and bone-in poultry.

Unique underflow pumping option eliminates air pockets beneath products for uniform coating.

Belt wiper and air knife keep excess batter in the applicator.

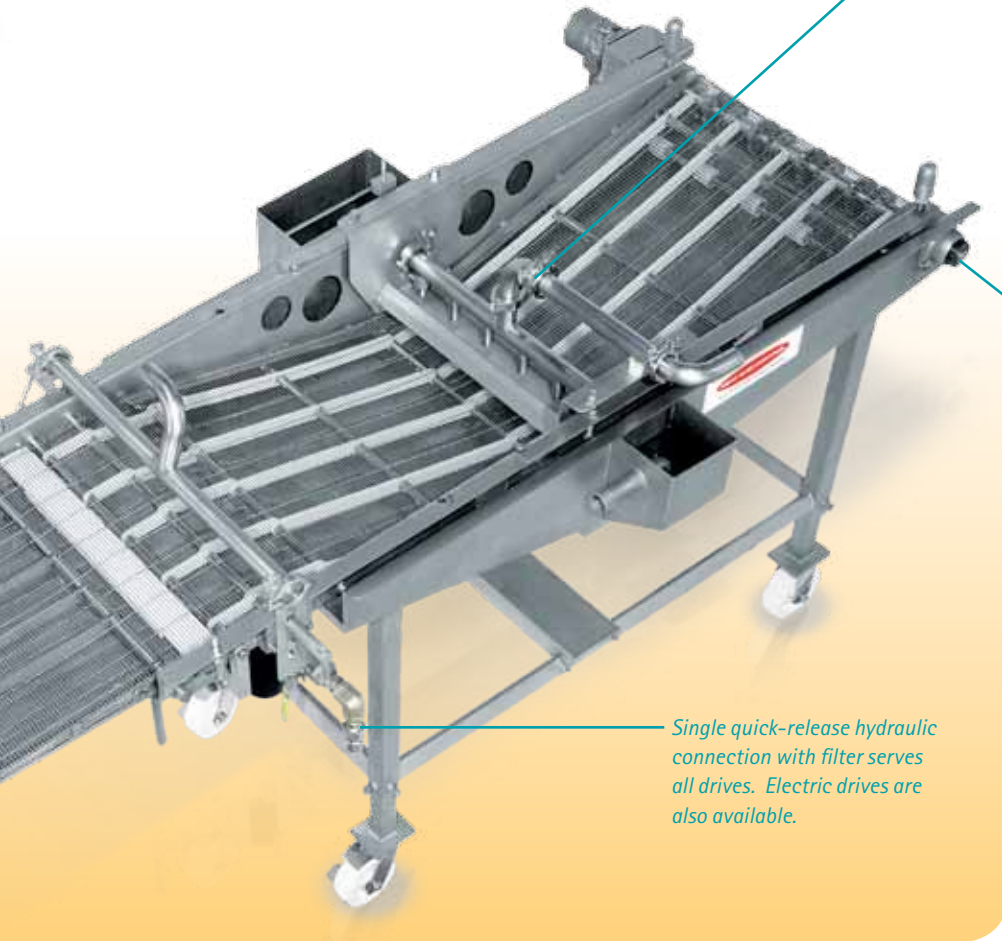

Permanently lubricated bearings reduce maintenance.

Single quick-release hydraulic connection with filter serves all drives. Electric drives are also available.

Heat and Control supplies the complete system plus worldwide parts and technical support.



Predust Batter Bread Convey Fry

Bake/Roast Brand/Sear Freeze

Package

SureCoat. Batter Applicator

Model BA

Heat and Control also builds customized modular coating systems for french fries, meat, poultry, seafood, and vegetable products



With a 96" wide belt, this 40,000 pounds/hour coating system is designed for 24-hour-a-day operation.

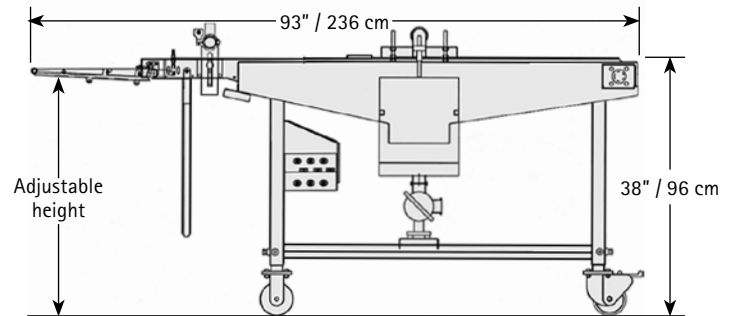

Standard Models	Belt Width	Usable Width	Overall Width
BA-28	28" / 71 cm	26" / 66 cm	50" / 127 cm
BA-36	36" / 91 cm	34" / 86 cm	62" / 157 cm
BA-42	42" / 107 cm	40" / 102 cm	68" / 173 cm

Dimensions are rounded to the nearest inch / centimeter.

Constant improvement and engineering innovations mean these specifications may change without notice.

HEAT AND CONTROL®

