

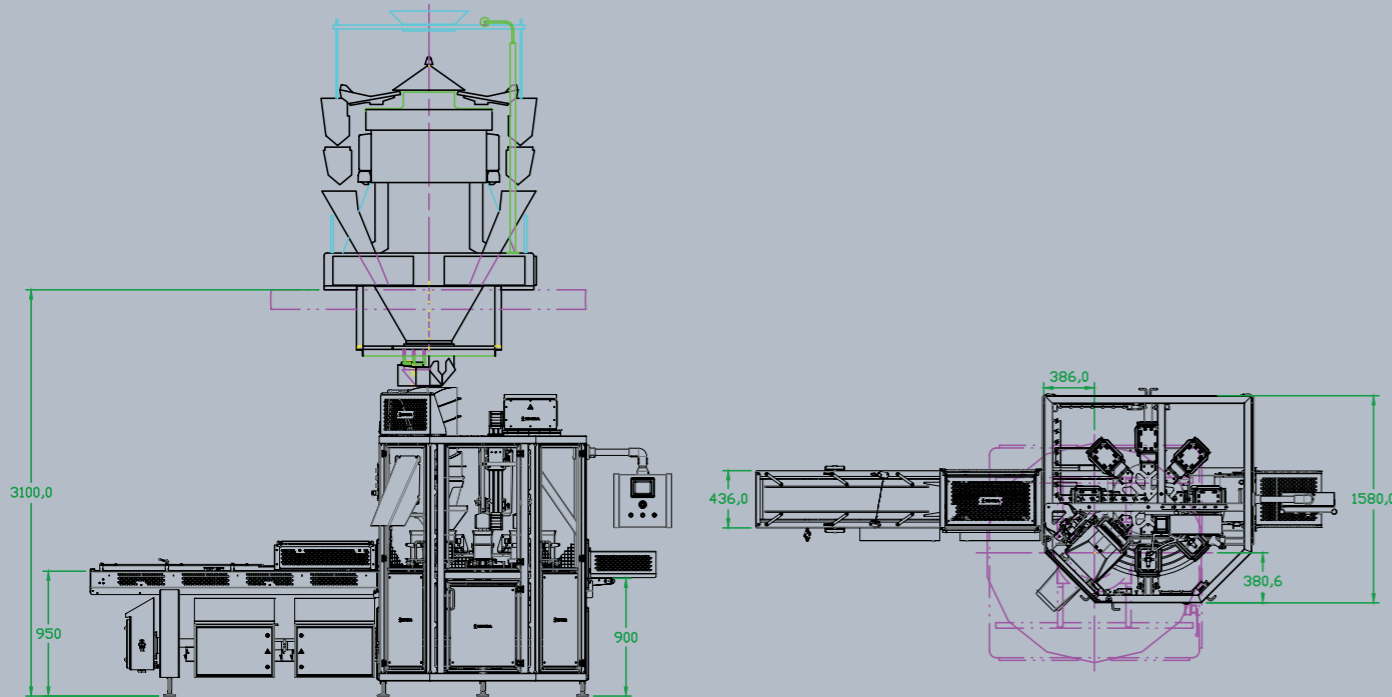

Ishida Rotary Salad Filler

Technical specification



Ishida Rotary Salad Filler

Automatically fills and tamps salad into preformed trays – minimum spillage, best tamping results and high speeds.

Ishida has extensive experience in weighing and packing salad products. Using the state of the art combination weighing combined with the latest proven technology for packing salad into trays.

- The Ishida Rotary Salad Filler accepts preformed trays which can be fed by hand or via automatic denesting.
- The filler then fills the tray via a Ishida combination weigher.
- The filler then tamps the product twice to ensure it is fully in the tray.
- Trays are lowered at the exit of the machine to ensure all product remains in the tray.

Ishida has now set the standard for salad weighing and filling in to preformed trays. The machine has been designed for the standard market sizes using quick release change parts.

- 5oz
- 7oz
- 10oz
- 11oz
- 16oz
- Other tray formats

Trays can be narrow or wide edge leading and are suitable for tray sealing, ultrasonic sealing or shrink banding.

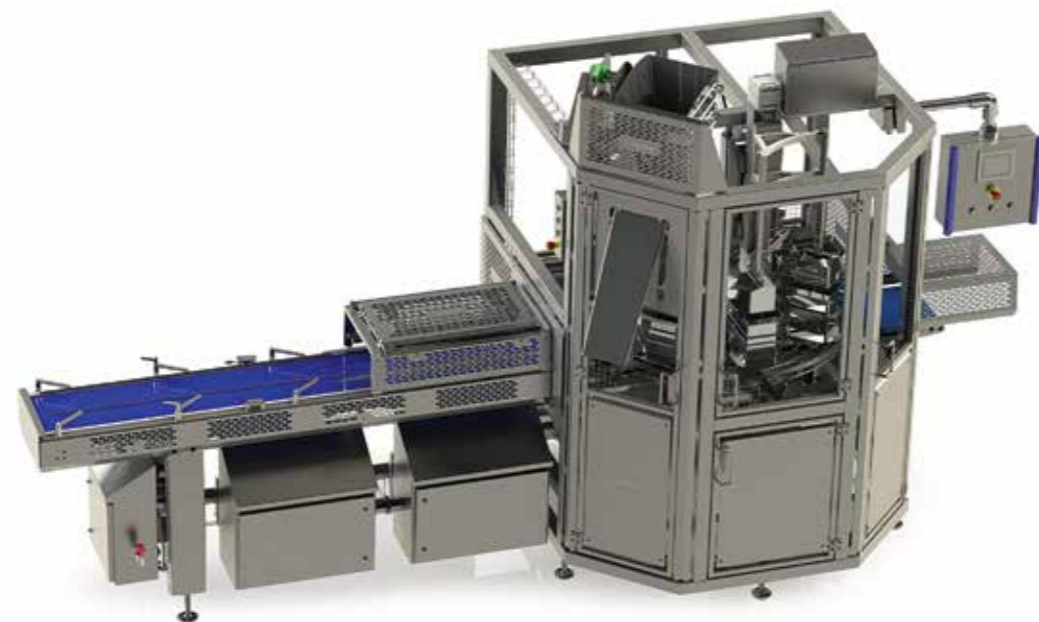

Main features



Stand alone machine

Machine is designed to be simple with its own control system. Integration with up and down-stream equipment is standard.



Infeed buffer

2 meter infeed conveyor to buffer the empty trays. This allows for greater efficiencies regardless which denester you choose.



Tray loading into Rotary hopper

Trays are loaded into the rotary hopper. These are rotated by the indexing table. Trays are also lifted during rotation to meet the hopper flange to prevent product spillage.

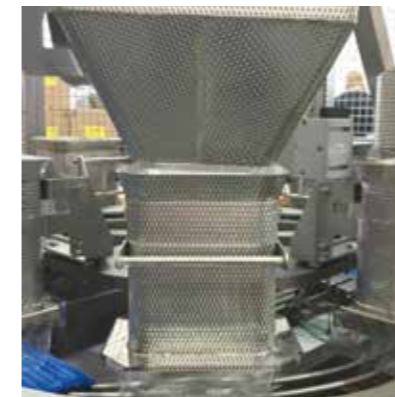

Fill point

Holding hopper and reject chute. Rotary hoppers are designed to receive product up to 3 times the volume of the tray



Two tamp stations

Product is tamped twice to ensure best results. The tamps are Ishida designed and use Ishida C4 material.



The best tamp results

All product is fully in the tray, minimum spillage, high speeds and best results in the industry.

Up to 50 trays per minute per lane on all pack formats