

## Rotary Can Filler

Precise, continuous motion & filling of dry free-flowing products into cans, jars & canisters.

### Fast, accurate filling

Continuously fill up to 90 containers per minute without jams, product spills or discharging empty containers.

### Jam-proof filling

A single lane conveyor delivers containers to multiple starwheels which positively position them beneath the rotating funnel wheel. Adjustable conveyor side guides assure containers advance through the filler without jams and downtime.

### No empty containers

Empty containers never pass through the system because the filler stops until the weigher is ready to discharge product.

### Eliminate product spills

If a container is not in position, product is not supplied to the funnel wheel. After filling, a vibrating plate gently settles product below the closure level before discharging containers.

### Adjustable can height

Easily adjust the funnel wheel for different container heights. Star and funnel wheels are also available for various container diameters.

### Simple maintenance

Stainless steel and plastic product contact surfaces are built for IP65 washdown. Lift-off safety shields allow complete access for cleaning and service.

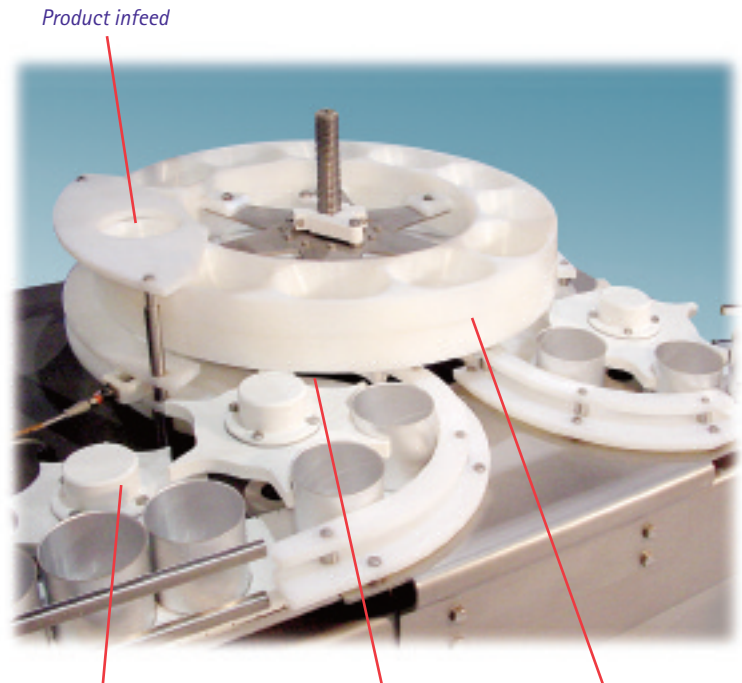

*Product infeed*

*Multiple starwheels positively index containers without jamming.*

*Cans nest into the funnel wheel to prevent product spills.*

*Funnel wheel is easily adjusted for different can heights.*



*Fully guarded for safety, shields easily lift off for complete access.*

# Rotary Can Filler | Model CF-Rotary

Easy-to-install parts allow the same Rotary Can Filler to be adjusted for a wide range of container heights and diameters.

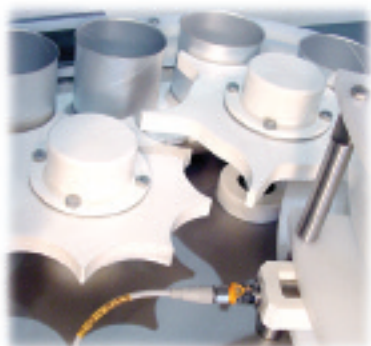

Funnel and starwheels are simply changed for different container sizes.

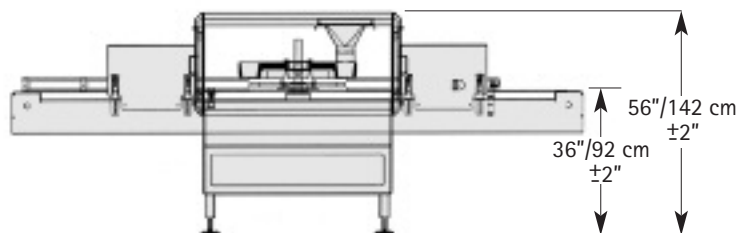
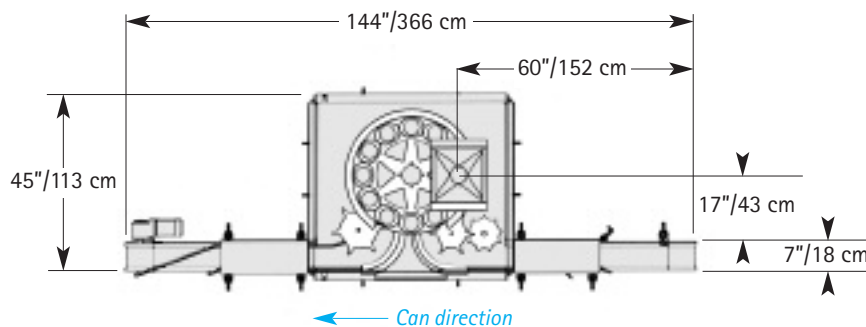
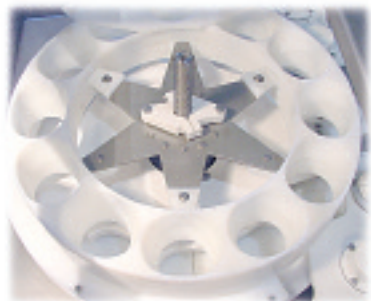

Dimensions are rounded to the nearest inch/centimeter.

Constant improvement and engineering innovations mean these specifications may change without notice.

**HEAT AND CONTROL**

