

# Uni-Spense<sup>®</sup> Dry Ingredient Distributor



*High Volume Uni-Spense III*

**Precisely distribute powders, granules and other products inside a coating drum, a blender, or over a conveyor belt.**

Uni-Spense can feed or distribute a variety of dry powders, granules, chopped, and shredded products. Its positive displacement auger and unique adjustable teardrop openings deliver a consistent metered supply of product.

"Tools-free" design greatly simplifies operation and changeover.

Uni-Spense III uses a 2" / 5.08cm feeder for high-volume production.

## Standard Features

- 304 stainless steel construction with Delrin auger
- "Tools-free" product changeovers
- NEMA 4 stainless steel control console with variable speed adjuster and digital readout
- Bridge-Buster<sup>™</sup> supply hopper with 1.5 cubic feet / .04 cubic meters capacity and adjustable cycle vibrator

## Options

- Powder Xpress<sup>™</sup> material transfer system
- Delta Dry<sup>™</sup> loss-in-weight system
- Custom length distribution tubes
- Solid core or open helix stainless steel auger
- Tube vibrator
- Deflector plate
- Portable stainless steel support stand with casters
- 4-20 mA or 0-10 volt DC input signal control



# Uni-Spense® Dry Ingredient Distributor

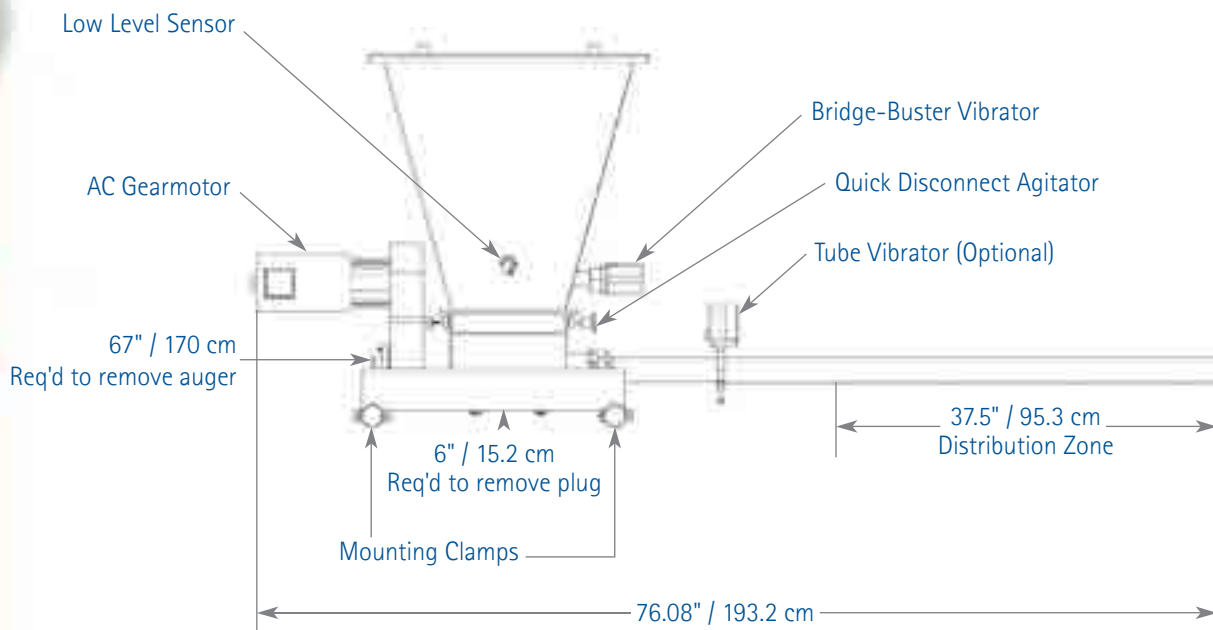

	Uni-Spense III
Hopper Capacity	2.5 cu. ft/ 0.07 cu. meters
Auger Diameter	2" / 5.08 cm

*Constant improvement and engineering innovations mean these specifications may change without notice.*



*Precisely adjust seasoning delivery with our simple Uni-Spense worm gear control.*



Heat and Control, Inc. 800 227 5980 [www.heatandcontrol.com](http://www.heatandcontrol.com)  
21121 Cabot Blvd., Hayward, CA 94545

Spray Dynamics 636 629 7366 [www.spraydynamics.com](http://www.spraydynamics.com)  
108 Bolte Lane, St. Clair, MO 63077

©October 2014 October Heat and Control, Inc.