

# Two-Stage Coating System



## Apply liquid and dry seasonings in one coating system

The Spray Dynamics two-stage coating system provides consistent, uniform application of liquid and dry coatings on extruded, baked, frozen, and fried products.

This complete and easy to operate coating system is engineered for proper dwell time and product-appropriate flight configuration. Made up of a Soft Flight<sup>®</sup> coating drum, a Micro-Meter I<sup>™</sup> airless liquid applicator, and a Uni-Spense<sup>®</sup> dry ingredient distributor, the two-stage coating system offers tools-free operation.

The gentle folding action of the Soft Flight<sup>®</sup> coating drum ensures that each piece of product is presented for seasoning application. Accurately metered and sprayed liquids, and precisely measured dry powders, provide reliable and even seasoning coverage.

### Standard Features

- Shell-in-shell coating drum
- Tools-free operation
- NEMA 4 stainless steel control console
- 304 stainless steel construction
- Painted steel, variable speed DC motors

### Options

- USDA Dairy finish or 316 stainless steel
- Variable speed AC motors
- Stainless steel motors
- Vibratory base feeder
- Powder on Demand<sup>™</sup> powder transfer system
- Loss-in-weight for liquid and powder systems
- Scarf Plate Distributor
- Easy Pull spray bar mount



# Two-Stage Coating System

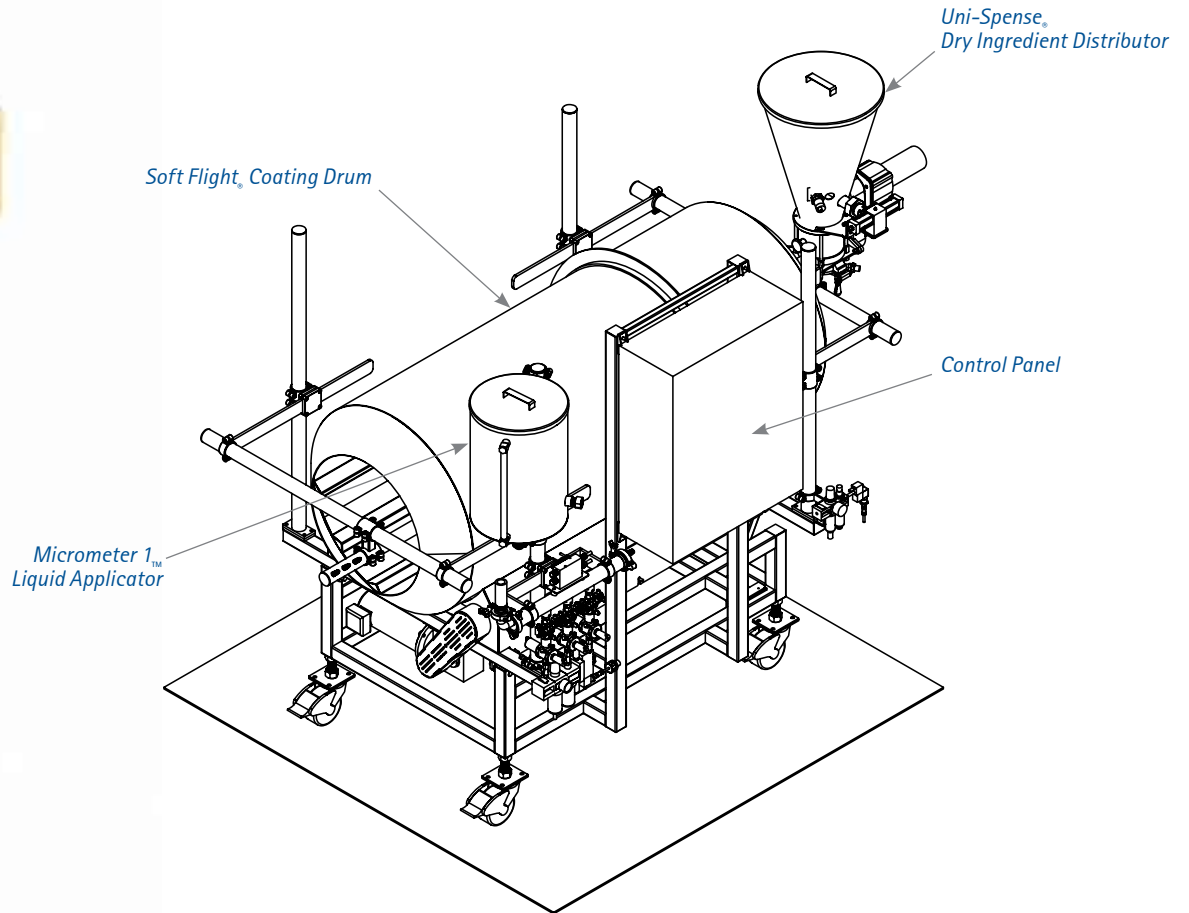

## Utilities

- 115/220V, 1ph, 60Hz
- 1.2 scfm at 80 psi per liquid applicator

*Constant improvement and engineering innovations mean these specifications may change without notice.*



Heat and Control, Inc. 800 227 5980 [www.heatandcontrol.com](http://www.heatandcontrol.com)  
21121 Cabot Blvd., Hayward, CA 94545

Spray Dynamics 636 629 7366 [www.spraydynamics.com](http://www.spraydynamics.com)  
108 Bolte Lane, St. Clair, MO 63077

©2012 Heat and Control, Inc.