



**FASTBACK®
CARTRIDGE PRECISION
SUPPORT SYSTEMS**

FASTBACK'S PLUG AND
PLAY SYSTEM OFFERS
COST AND TIME SAVINGS

HEAT AND CONTROL

®

www.heatandcontrol.com

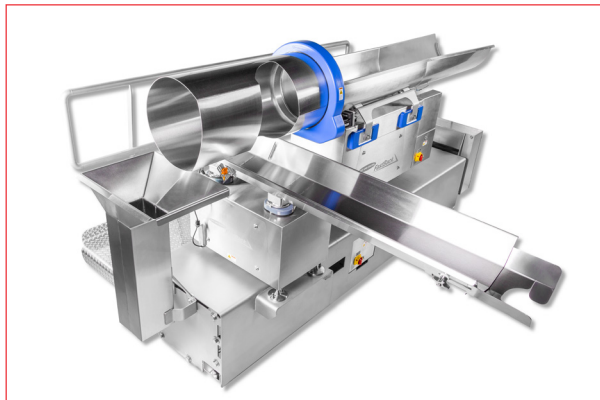
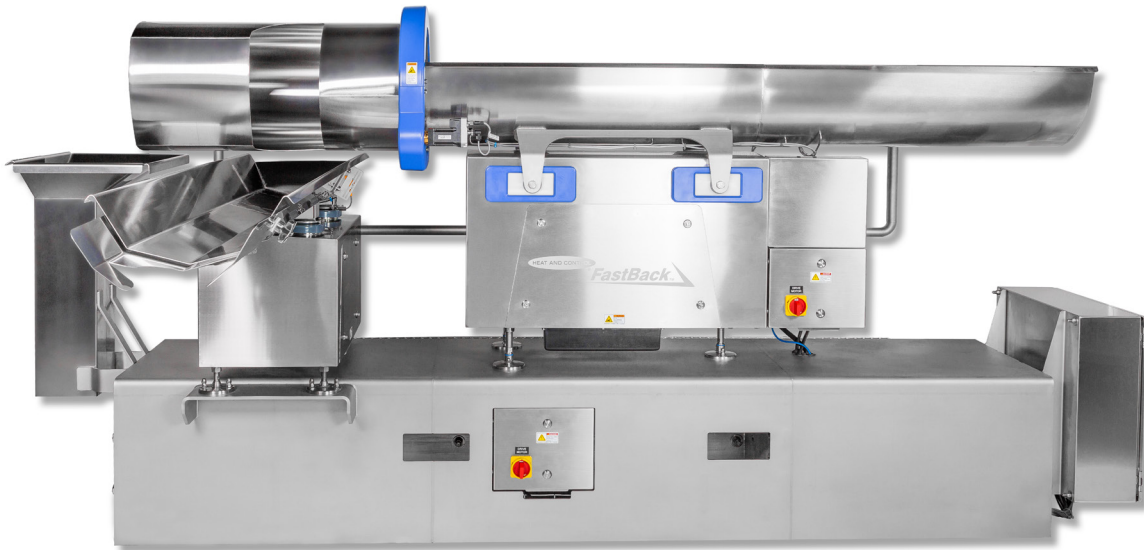

REDUCE TIME AND COST, NOT QUALITY

Purchasing the best processing equipment is an investment, and to offset the expense, manufacturers sometimes compromise and purchase generic supporting structures. However, the total expense of generic materials, installation, shipping, and delays may exceed any potential savings if the supporting structures do not align precisely with equipment.

The FastBack Cartridge Precision Support System (Cartridge PSS) allows manufacturers to source cost-effective local access platforms while providing a pre-engineered, pre-wired, and pre-piped modular support structure that is precisely aligned with FastBack distribution equipment. Use of local non-precision access platforms can reduce significantly total cost and commissioning and installation time.

SANITATION AND STANDARDS

The Cartridge PSS is compliant to American Meat Institute (AMI) principles of sanitary design. In summary, the ten (10) AMI sanitary equipment design principles are:

1. Surfaces are cleanable to a microbiological level
2. Materials used in construction are compatible
3. Parts are accessible for inspection, maintenance, cleaning, and sanitation
4. Product or liquid does not collect
5. Hollow areas are hermitically sealed
6. Surfaces are niche-free
7. Operations are performed in a sanitary manner
8. Maintenance enclosures are hygienic designed
9. Other plant systems are hygienic compatible
10. Cleaning and sanitizing protocols are validated

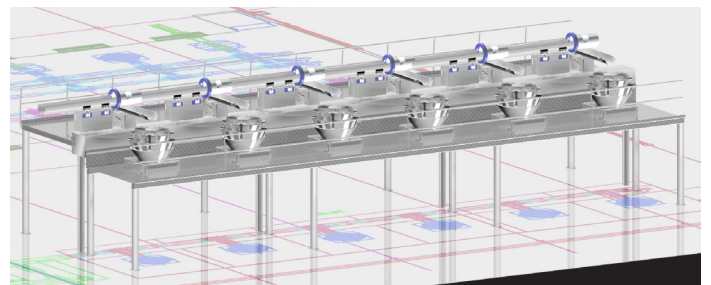
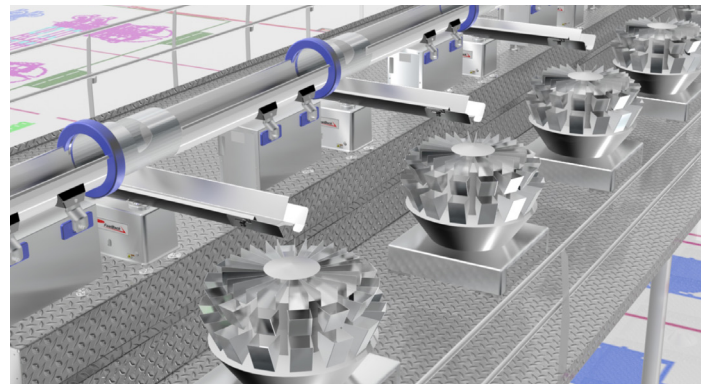
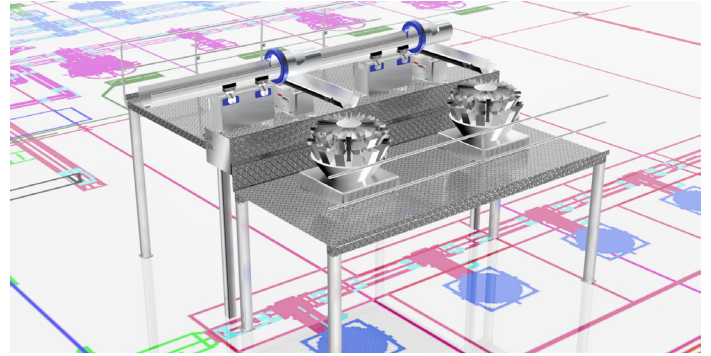

PERFORMANCE | QUALITY | VALUE

BENEFITS

Plug and play

Avoid unexpected delays and costs– Cartridge PSS' pre-engineered, pre-wired modules ensure access platforms are a perfect fit to the FastBack system.

Modular

Reclaim the costly loss of production time commonly associated with traditional onsite-built support steel.

Expandable

Future-proof the support steel investment with easily expandable modular design as needed.

FASTBACK CARTRIDGE PRECISION SUPPORT SYSTEMS

The Cartridge PSS is not an access platform; it is designed to couple with any adequate supporting structure to ensure precise integration of FastBack distribution systems with access platforms, eliminating costly integration errors caused by generic access platform manufacturers. The Cartridge PSS improves finished system quality, reduces commissioning and installation time, and allows local sourcing of non-precision/critical support steel, reducing total cost significantly.

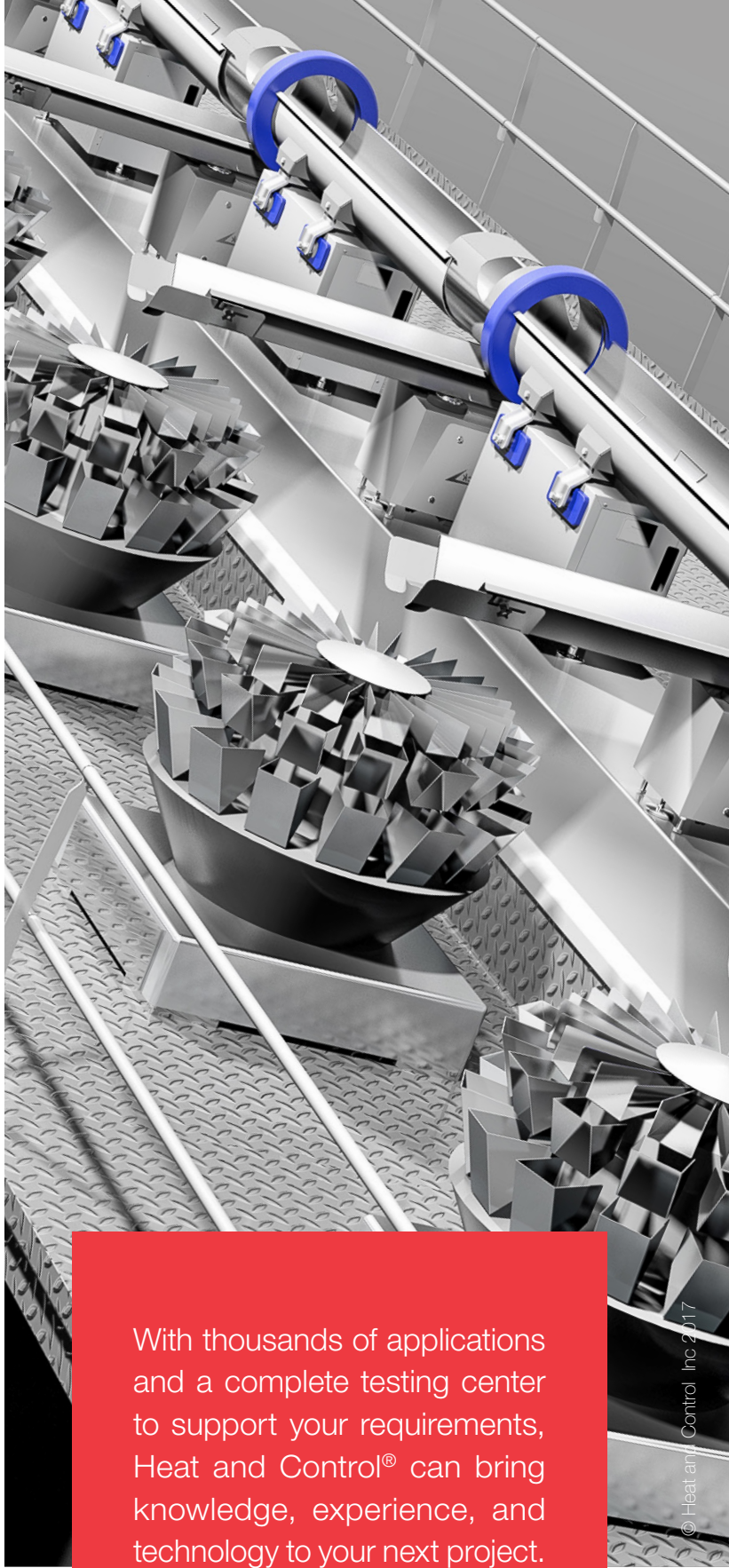

With thousands of applications and a complete testing center to support your requirements, Heat and Control® can bring knowledge, experience, and technology to your next project.

HEAT AND CONTROL

®

www.heatandcontrol.com | info@heatandcontrol.com