

FastBack[®]

Solutions



Upgrade[™] Accumulation Conveyor

■ Problem

High efficiency weighing and packaging systems require just the right amount of product accumulation for optimum performance. Too little accumulation between processing and packaging results in wasteful manual bulk-off of product. Excessive accumulation causes thawing and product degradation, significantly reducing product quality, line efficiency and profits.

■ Solution

FastBack's new Upgrade conveyor improves packaging efficiency by delivering a steady supply of frozen product to weighers and other packaging machinery. Upgrade eliminates costly bulk-offs by maintaining a buffer between processing and packaging. Product is metered to downstream equipment at a consistent rate to prevent thawing. Upgrade's gentle horizontal conveying motion minimizes product damage and coating loss.

■ Benefit

- Eliminates product thawing and labor-intensive pour-back.
- Gentle horizontal motion eliminates product spillage and minimizes product breakage and coating loss.
- Customized pans with fully-welded construction clean up quickly and fit any product application. All FastBacks are ruggedly built to insure dependable product distribution in the harshest factory environments.
- FastBack's patented drive system eliminates chains, cables, and moving parts from in or around the product area, simplifying maintenance and sanitation.
- No complicated operator fine tuning of vibratory conveyors.
- Installation costs are minimal. Simply set the FastBack drive unit in place, mount the pan, and power-up. Noise levels are below 70 dB, making FastBacks the quietest conveyors on the market.

HEAT AND CONTROL[®]



Upgrade™ Accumulation Conveyor

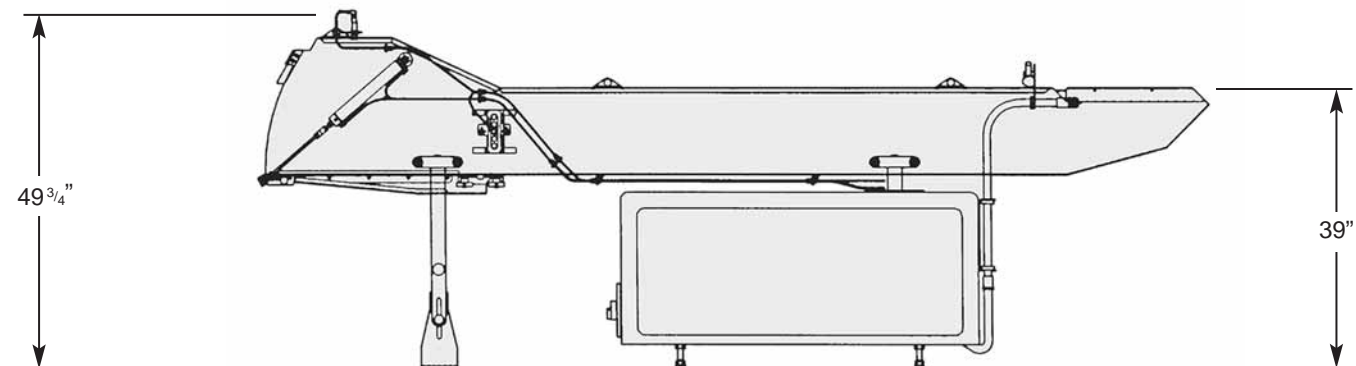
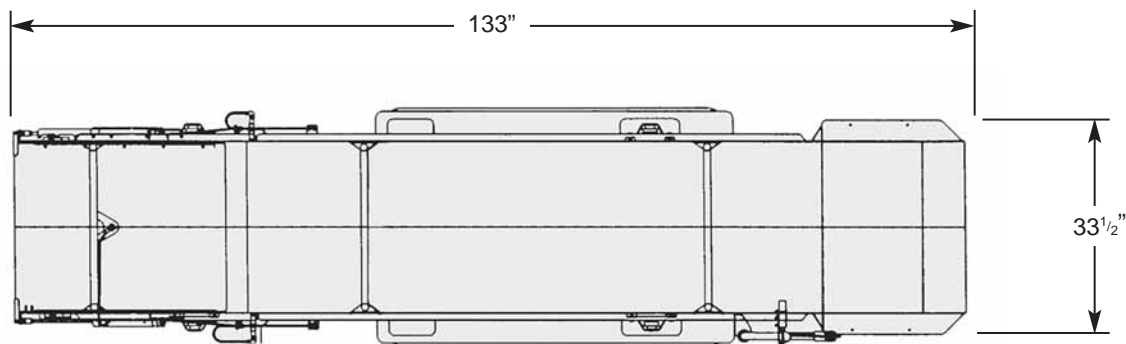

Constant improvement and engineering innovations mean these specifications may change without notice.

HEAT AND CONTROL

®



Headquarters
 21121 Cabot Blvd., Hayward, CA 94545 USA
 Tel 1 800 227 5980 / 1 510 259 0500 Fax 1 510 259 0600

Campbellville, Canada
 Tel 905 854 5650 Fax 905 854 5653

Guadalajara, Mexico
 Tel +52 (33) 3689 1146 Fax +52 (33) 3689 2240

Livingston, Scotland
 Tel +44 (0)1506 420420 Fax +44 (0)1506 403919

Brisbane, Australia
 Tel +61 (0)7 3877 6333 Fax +61 (0)7 3343 8371

Singapore
 Tel +65 6273 6362 Fax +65 6273 8161

Over 30 Offices Worldwide www.heatandcontrol.com • info@heatandcontrol.com • ©2006 Heat and Control, Inc.