

THS/PL

Industrial metal detector
for liquid and viscous products



CALL TOLL-FREE 800 227 5980

Phone 510 259 0500 Fax 510 259 0600

info@heatandcontrol.com

HEAT AND CONTROL

www.heatandcontrol.com



Very high sensitivity to all magnetic and non-magnetic metals, including stainless steel

Full compliance with **HACCP** criteria

Standard pipe sizes available to suit all applications

Completely housed in **AISI 316L** stainless steel

Easy to clean and inspect

Minimum installation space required

Very high reliability

THS/PL

Industrial metal detector for liquid and viscous products

www.ceia.net



The THS/PL System is designed for metal contaminant detection in products transported by pipeline, especially meat, soup and preserves. Digital Signal Processing (DSP) of the Metal Detector Antenna signals allows a very high degree of sensitivity to be achieved for all metals.

The carefully selected materials used in construction do not interact with food products, and thus do not modify or alter their composition.

The construction guarantees quick, easy cleaning of the components that are in contact with the product. The technological choices made by CEIA allow the parts in contact with the product to be disassembled and maintained in a short time.

The structure, equipped with casters, provides ease of installation and maintenance. The working height can easily be modified by manual unlocking and adjustment supported gas spring. THS/PL system can be linked to local computer networks via a RS-485, RS-232 interface.

Technical Specifications

General Features

- Stainless steel AISI 316L and FDA approved plastic composition for all parts in contact with the product
- Fast disassembly and cleaning
- Very high throughput

Metal Detection Features

- Very high sensitivity to ferrous, non-ferrous and stainless steel metals
- Very high immunity to external electrical and mechanical interferences
- Automatic balancing
- Built-in self diagnosis system

Production Data Management

- Complete production logging (using dump of the internal memory or THS Report):
 - Ejections
 - Test results
 - Parameters modification
- Network Interface: RS-485

Signaling

- Acoustic
- Optical

Programming

- Local: Keyboard and 80 character LCD display
- Remote via RS-232 , RS-485

I/O and Environmental Data

- Power supply: 115/230 VAC, -22%/+10 %, 48-62 Hz, 60 VA
- Operating Temperature: from 14°F (-10°C) to 131°F (+55°C)
- Relative humidity: 0-95% (without condensation)
- Relay outputs
 - Ejection
 - Test request
 - Fault
- Direct RS-232 connection to printer or personal computer

Certification and Conformity

- Conforms to current requirements for pipeline metal detection systems.
- Complies with EC regulations and international standards relating to electrical safety and electromagnetic compatibility.

MODEL	CLAMP DIAMETER	
	INCH	mm
THS/PL-38	1.5"	38
THS/PL-50	2"	50
THS/PL-63	2.5"	63
THS/PL-75	3"	75
THS/PL-100	4"	100

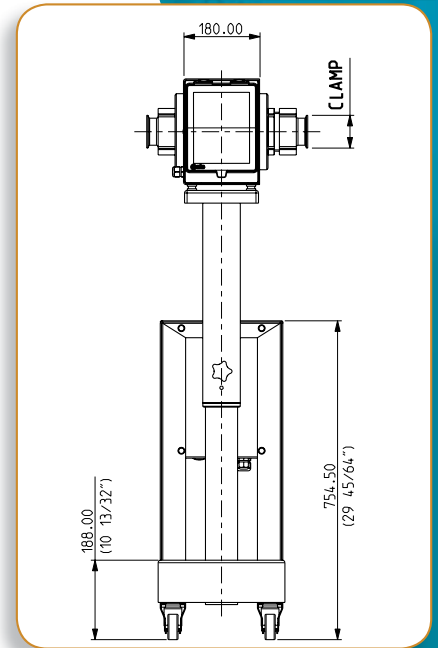

THS/PL-XX FRONT VIEW

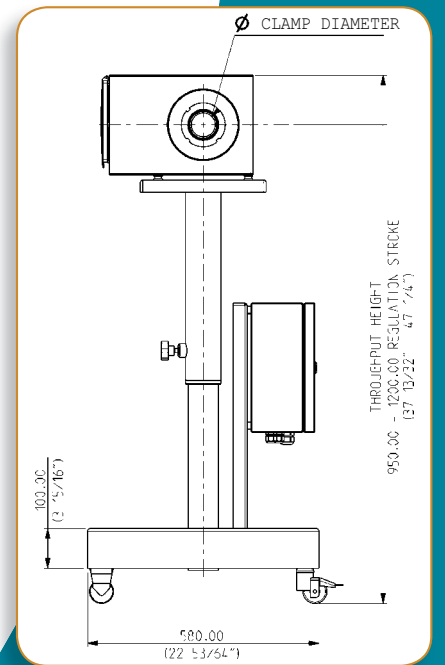

THS/PL-XX SIDE VIEW



21121 Cabot Blvd. Hayward, CA 94545 USA
Tel 1 800 227 5980 / 1 510 259 0500 Fax 1 510 259 0600
info@heatandcontrol.com

www.heatandcontrol.com