

Rotary Can Filler

Precise, continuous motion & filling of dry free-flowing products into cans, jars & canisters.

Fast, accurate filling

Continuously fill up to 90 containers per minute without jams, product spills or discharging empty containers.

Jam-proof filling

A single lane conveyor delivers containers to multiple starwheels which positively position them beneath the rotating funnel wheel. Adjustable conveyor side guides assure containers advance through the filler without jams and downtime.

No empty containers

Empty containers never pass through the system because the filler stops until the weigher is ready to discharge product.

Eliminate product spills

If a container is not in position, product is not supplied to the funnel wheel. After filling, a vibrating plate gently settles product below the closure level before discharging containers.

Adjustable can height

Easily adjust the funnel wheel for different container heights. Star and funnel wheels are also available for various container diameters.

Simple maintenance

Stainless steel and plastic product contact surfaces are built for IP65 washdown. Lift-off safety shields allow complete access for cleaning and service.

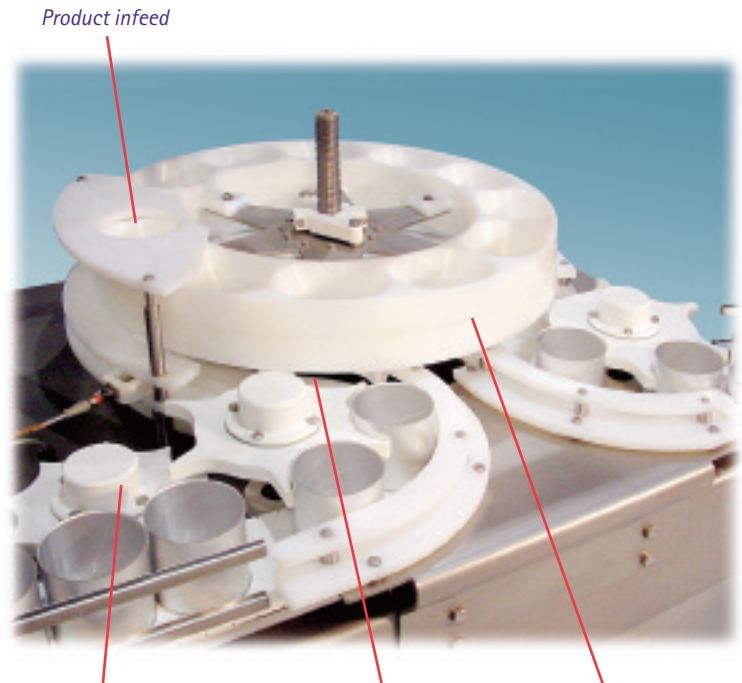

Product infeed

Multiple starwheels positively index containers without jamming.

Cans nest into the funnel wheel to prevent product spills.

Funnel wheel is easily adjusted for different can heights.



Fully guarded for safety, shields easily lift off for complete access.

Rotary Can Filler | Model CF-Rotary

Easy-to-install parts allow the same Rotary Can Filler to be adjusted for a wide range of container heights and diameters.

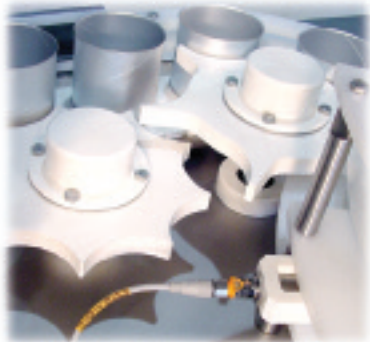

Funnel and starwheels are simply changed for different container sizes.

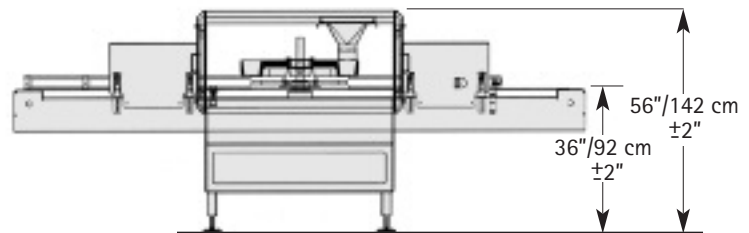
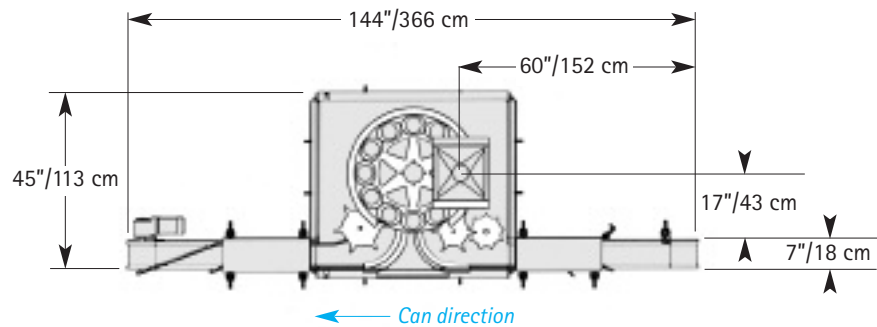
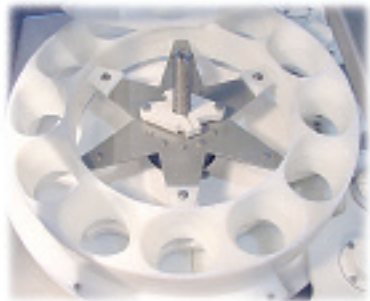

Dimensions are rounded to the nearest inch/centimeter.

Constant improvement and engineering innovations mean these specifications may change without notice.

HEAT AND CONTROL

®



Headquarters
 21121 Cabot Blvd., Hayward, CA 94545 USA
 Tel 1 800 227 5980 / 1 510 259 0500 Fax 1 510 259 0600
 Guadalajara, Mexico
 Tel 52 33 3689 1146 Fax 52 33 3689 2240
 Livingston, Scotland
 Tel +44 (0)1506 420420 Fax +44 (0)1506 403919
 Schwaz-Vomperbach, Austria
 Tel +43 5242 66751 Fax +43 5242 66752
 Brisbane, Australia
 Tel +61 (0)7 3877 6333 Fax +61 (0)7 3343 8371
 Singapore
 Tel +65 6273 6362 Fax +65 6273 8161

Over 30 Offices Worldwide www.heatandcontrol.com • info@heatandcontrol.com • ©2003 Heat and Control, Inc.