

HEAT AND CONTROL

®

Mastermatic® Snack Food Fryer



*Standard fryers are available with
12 to 65 sq. ft. of frying area.*

Automated continuous frying for a variety of snack food products.

Precise frying control

Accurately control temperature and conveyor speed for consistently uniform products including:

Tortilla Chips	Soy and Wheat Nuts	Corn Chips
Cheese Balls	Pasta Snacks	Pork Rinds
Pellet Snacks	Vegetable Snacks	Noodles

Superior quality products

Low oil volume provides fast oil turnover rates for fresh, crisp products with a longer shelf life. Unique Mastermatic Cool Zone™ extends oil life.

Easy installation

All models are pre-wired and include operating controls. Fryer systems can be delivered pre-piped to reduce the cost of installation.

Maximum versatility

A variety of conveyor belts are available for different products. All models feature multiple heating zones for optimal temperature control.

Minimal floor space

Mastermatic fryers provide a large frying area from a relatively small foot print.

Easy cleaning

Main and submerger conveyors separate and raise clear of the pan to facilitate cleaning. Fryer can be built to USDA standards for meat snacks.

Optional Features

- Continuous oil filter
- Sediment removal conveyor
- Automatic oil level control
- Fire suppression components
- Packaging systems

Mastermatic® Snack Food Fryer | Model MSFF

Choose from our standard conveyor designs or let us custom design a fryer for your unique snacks.

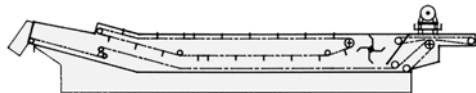

Buoyant product *Drop-in product feed.*
 Corn and tortilla chips, cheese balls, puff pellet snacks, noodles, french fries, pasta.



Free-flowing product *Nuts, sunflower seeds, soy and wheat nuts, pellet snacks, vegetable snacks, beans, pasta snacks.*

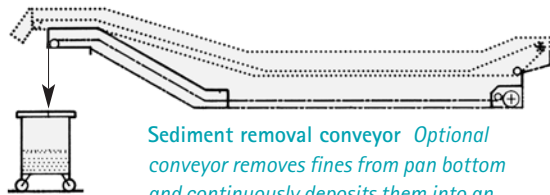

Sediment removal conveyor *Optional conveyor removes fines from pan bottom and continuously deposits them into an external container. Note: Adds approximately 5 feet to fryer length.*

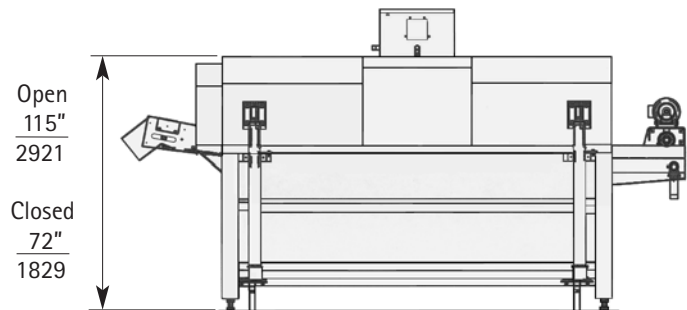

Standard Model Examples	Heating Zones	Overall Length feet/meters	Overall Width inches/mm
8-24	2	11' / 3.36	60" / 1524
10-24	2	13' / 3.97	60" / 1524
8-30	2	11' / 3.36	66" / 1676
28-30	3	31' / 9.46	66" / 1676
8-36	2	11' / 3.36	72" / 1829
36-36	3	39' / 11.90	72" / 1829
8-42	2	11' / 11.36	78" / 1981
32-42	3	35' / 10.68	78" / 1981

Fryer lengths are available in 2' (.6m) increments up to 36' (11m) long with useable belt widths up to 40" (1016mm).

Constant improvement and engineering innovations mean these specifications may change without notice.



**Over 30 Offices Worldwide
 Contact Us For The Location Nearest You**

North and South America Heat and Control, Inc.
 21121 Cabot Blvd., Hayward, CA 94545-1132 USA
 Tel 1 800 227 5980 / 1 510 259 0500 Fax 1 510 259 0600

Mexico Heat and Control, S. A. de C.V.
 Circuito Productividad Sur 107 Parque Industrial
 Guadalajara, El Salto, Jalisco 45690 Mexico
 Tel +52 3 689 1146 Fax +52 3 689 2240

Europe, Africa, CIS, Middle East Heat and Control, Ltd.
 Starlaw Park, Livingston, W. Lothian, EH54 8SF Scotland
 Tel +44 (0)1506 605555 Fax +44 (0)1506 605599

Australia, New Zealand, Asia Heat and Control Pty., Ltd.
 407 Creek Rd., Mt. Gravatt, Brisbane 4122, Qld., Australia
 Tel +61 (0)7 3877 6333 Fax +61 (0)7 3343 8371

www.heatandcontrol.com
info@heatandcontrol.com
 ©1999 Heat and Control, Inc.

MASTERMATIC®

HEAT AND CONTROL®