

HEAT AND CONTROL

®

Mastermatic® Nut Roasting System

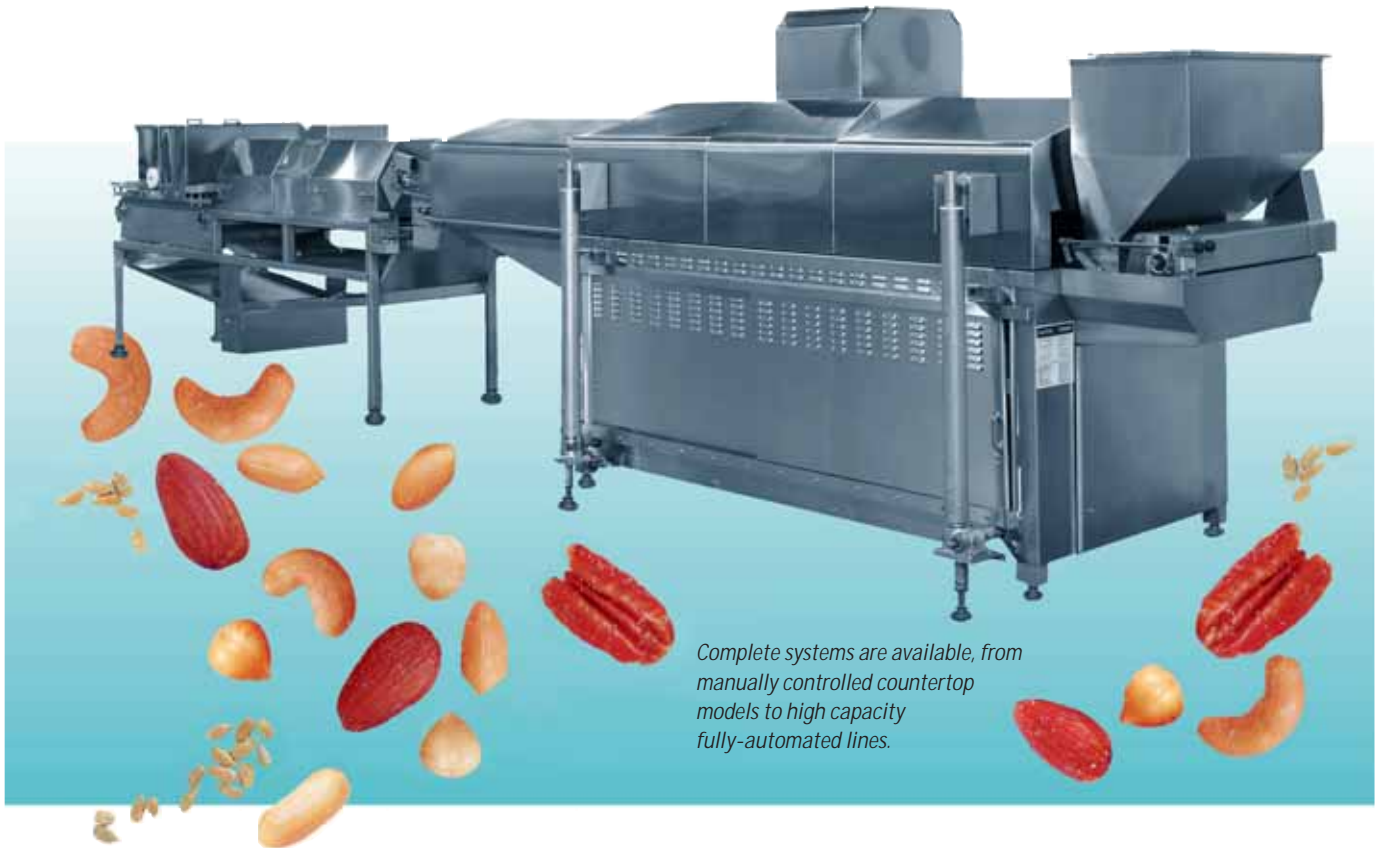

Complete systems are available, from manually controlled countertop models to high capacity fully-automated lines.

One turnkey system continuously processes every variety of nut meat.

Everything from product infeed to oil roasting, cooling, glazing, seasoning and controls are provided in a single ready-to-run system.

Superior product quality

The world's leading nut processors rely on Mastermatic systems for consistent, high quality product. Direct-heating without hot spots and the unique Mastermatic Cool Zone™ promote oil and product quality.

Precise process control

Independent control of product feed, multiple temperature zones in the roaster, conveyor speeds, glazing and seasoning application provide customized processing for any variety of nut.

Easy-to-clean

Drip pans and covers are easily removed for complete cleaning access. The unique cooler design prevents seasoning build-up on the conveyor belt.

Easy installation

All models are pre-wired and include operating controls. To reduce installation cost, systems can be delivered pre-piped and ready for operation.

Optional Features

- Continuous oil filter
- Sediment removal conveyor
- Submerger conveyor
- Automatic oil level control
- Conveyor/hood hoists
- Tumble drum seasoner
- Fire suppression components
- Conveying and packaging systems

Mastermatic® Nut Roasting System | Model NC

From compact to high capacity, Mastermatic Nut Roasting Systems are available in sizes to meet your unique production requirements.



The world's leading nut processors rely on Mastermatic Nut Roasting Systems for reliable operation and consistently high product quality.

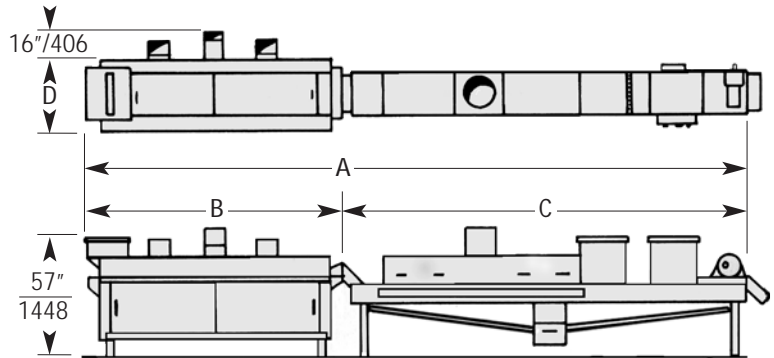

Constant improvement and engineering innovations mean these specifications may change without notice.

Standard Model Examples	A feet/meters	B feet/meters	C feet/meters	D inches/mm	Heating Zones
8-24	22' / 6.7	10' / 3.05	12' / 3.7	60" / 1524	2
10-30	26' / 7.9	12' / 3.66	14' / 4.3	66" / 1676	2
16-30	39' / 11.9	18' / 5.49	21' / 6.4	66" / 1676	2
18-34	44' / 13.4	20' / 6.10	24' / 7.3	70" / 1778	2
24-34	54' / 16.5	26' / 7.93	28' / 8.5	70" / 1778	3
28-40	62' / 18.9	30' / 9.15	32' / 9.8	76" / 1930	3

Fryer lengths are available in 2' (.6m) increments up to 36' (11m) long with useable belt widths up to 40" (1016mm) wide. Dimensions shown are approximate.



HEAT AND CONTROL



Headquarters
 21121 Cabot Blvd., Hayward, CA 94545 USA
 Tel 1 800 227 5980 / 1 510 259 0500 Fax 1 510 259 0600
 Guadalajara, Mexico
 Tel 52 33 3689 1146 Fax 52 33 3689 2240
 Livingston, Scotland
 Tel +44 (0)1506 420420 Fax +44 (0)1506 403919
 Schwaz-Vomperbach, Austria
 Tel +43 5242 66751 Fax +43 5242 66752
 Brisbane, Australia
 Tel +61 (0)7 3877 6333 Fax +61 (0)7 3343 8371
 Singapore
 Tel +65 6273 6362 Fax +65 6273 8161

Over 30 Offices Worldwide www.heatandcontrol.com • info@heatandcontrol.com • ©2004 Heat and Control, Inc.