

HEAT AND CONTROL

®

Mastermatic® Prepared Foods Fryer

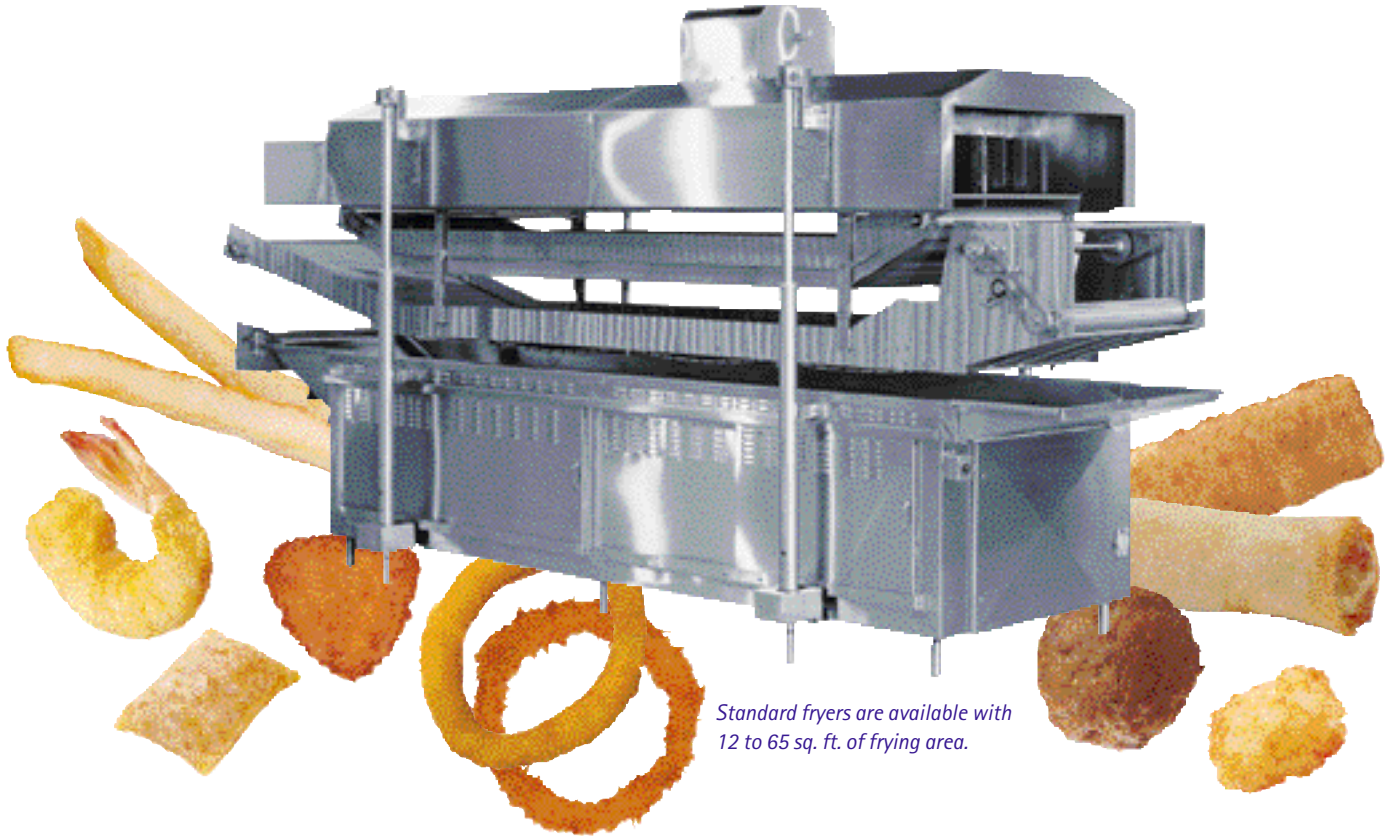

Standard fryers are available with 12 to 65 sq. ft. of frying area.

Automated continuous frying for a variety of prepared food products.

Precise frying control

Accurately control temperature and conveyor speed for consistently uniform products including:

Chicken Nuggets	Coated Vegetables	Eggrolls
French Fries	Tempura Products	Hash Browns
Seafoods	Meatballs and Patties	Fried Pies

Superior product quality

Low oil volume provides fast oil turnover rates for fresh, crisp products with a longer shelf life. Unique Mastermatic Cool Zone™ extends oil life.

Maximum versatility

A variety of conveyor belts are available for different products. All models feature multiple heating zones for optimal temperature control.

Easy installation

All models are pre-wired and include operating controls. Fryer systems can be delivered pre-piped to reduce the cost of installation.

Minimal floor space

Mastermatic fryers provide a large frying area from a relatively small footprint.

Easy cleaning

Main and submerger conveyors separate and raise clear of the pan to facilitate cleaning. Fryer is built to USDA standards.

Optional features

- Continuous oil filter
- Sediment removal conveyor
- Automatic oil level control
- Fire suppression components
- Coating systems
- Packaging systems

Mastermatic® Prepared Foods Fryer

Model MPFF

Choose from our standard conveyor designs or let us custom design a fryer for your unique products.



Non-buoyant product *Meatballs, bone-in chicken, deli loaves.*



Fragile semi-buoyant product *Meat patties, vegetables, clams, eggrolls, eggplant, fish.*



Tempura coated product *Fish and chicken nuggets, shrimp, potato pancakes, pockets.*



Sediment removal conveyor *Optional conveyor removes fines from pan bottom and continuously deposits them into an external container. Note: Adds approximately 5 feet to fryer length.*

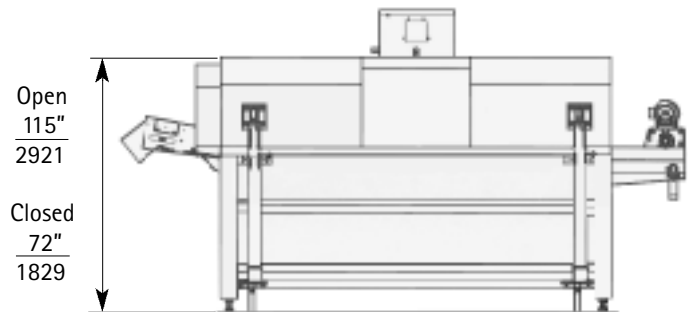

Standard Model Examples	Heating Zones	Overall Length feet/meters	Overall Width inches/mm
8-24	2	11' / 3.36	60" / 1524
10-24	2	13' / 3.97	60" / 1524
8-30	2	11' / 3.36	66" / 1676
28-30	3	31' / 9.46	66" / 1676
8-36	2	11' / 3.36	72" / 1829
36-36	3	39' / 11.90	72" / 1829
8-42	2	11' / 11.36	78" / 1981
32-42	3	35' / 10.68	78" / 1981

Fryer lengths are available in 2' (.6m) increments up to 36' (11m) long with useable belt widths up to 40" (1016mm).

Constant improvement and engineering innovations mean these specifications may change without notice.



HEAT AND CONTROL



Headquarters
21121 Cabot Blvd., Hayward, CA 94545 USA
Tel 1 800 227 5980 / 1 510 259 0500 Fax 1 510 259 0600

Campbellville, Canada
Tel 905 854 5650 Fax 905 854 5653

Guadalajara, Mexico
Tel +52 (33) 3689 1146 Fax +52 (33) 3689 2240

Livingston, Scotland
Tel +44 (0)1506 420420 Fax +44 (0)1506 403919

Brisbane, Australia
Tel +61 (0)7 3877 6333 Fax +61 (0)7 3343 8371

Singapore
Tel +65 6273 6362 Fax +65 6273 8161

Over 30 Offices Worldwide

www.heatandcontrol.com • info@heatandcontrol.com • ©2005 Heat and Control, Inc.