

HEAT AND CONTROL

®

Hydraulic Extruder

Space-saving vertical extruder forms uniform lengths of corn chips and other snacks.

Semiautomatic operation

Extrusion starts automatically after dough is manually loaded and the cylinder is locked in position. When the cylinder is empty, the piston retracts for refilling. Optional drive system automatically pivots cylinder in and out of extrusion position.

Versatile extruding

Easily interchangeable dies let you form products in different shapes and sizes. Bottom-out insert and custom dies are available for unique products.

Easy loading & cleaning

Cylinder swings 90° to the side for simple filling, die changes and cleaning.

Safety first

Piston descends only after cylinder is locked in position. Shields guard the rotary cutoff assembly.

Rugged construction

Extruder piston, heat-treated cylinder, and epoxy painted base are crafted from carbon steel.

Dough cylinder swings open 90° for easy filling. Extrusion starts automatically when cylinder is closed.

Standard side-out dies are easily interchangeable with optional bottom-out insert or customized dies.

Rugged base is available with one or two extrusion heads.

Extruder includes a 3,000 psi hydraulic power pack, pre-piped, wired and ready for remote location.

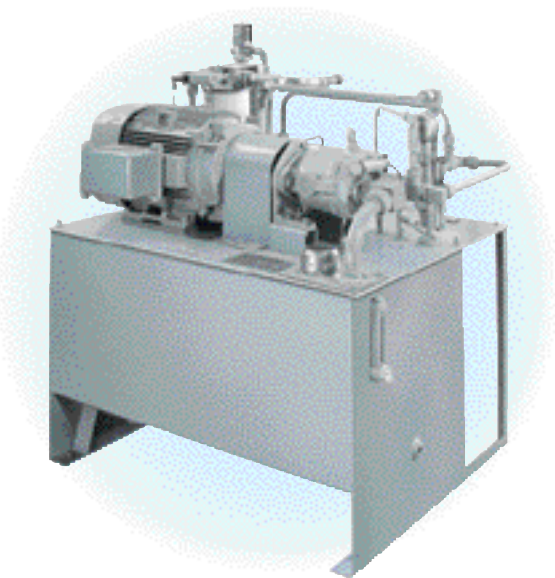
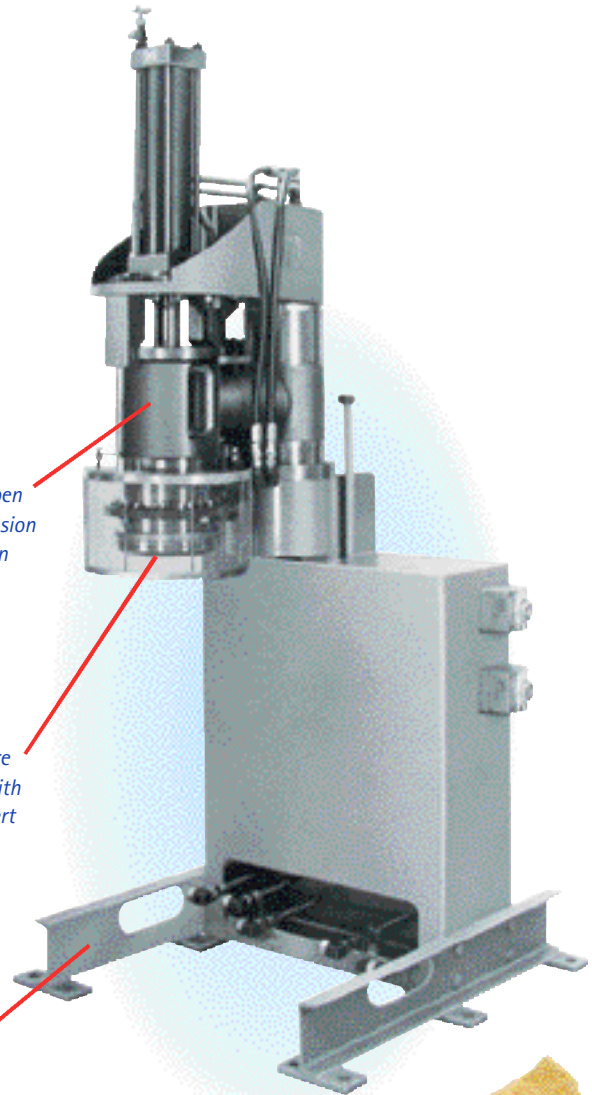

Hydraulic Extruder | Model HE

Choose standard models for up to 2,000 lbs/hr of finished corn chips, or customize an extruder for your unique products.

Optional features

- Two extrusion cylinders
- Dies for custom product shapes
- Automatic cylinder drive system
- Pre-compaction system to expel air from dough before extrusion



Heat and Control also builds complete systems for raw corn cooking, sheeting, toasting, frying, seasoning & packaging.

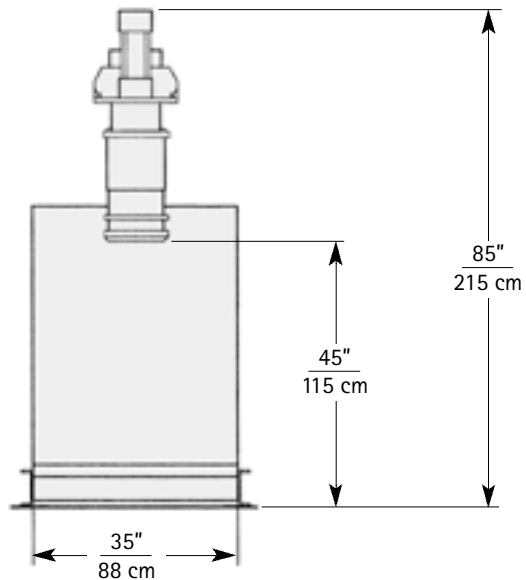
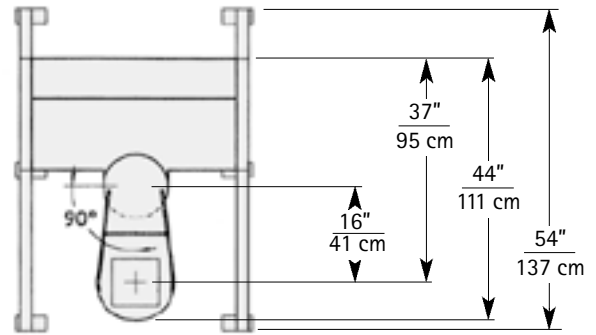

Dimensions are rounded to the nearest inch/centimeter.

Constant improvement and engineering innovations mean these specifications may change without notice.

HEAT AND CONTROL



Headquarters
21121 Cabot Blvd., Hayward, CA 94545 USA
Tel 1 800 227 5980 / 1 510 259 0500 Fax 1 510 259 0600

Guadalajara, Mexico
Tel 52 33 3689 1146 Fax 52 33 3689 2240

Livingston, Scotland
Tel +44 (0)1506 420420 Fax +44 (0)1506 403919

Schwaz-Vomperbach, Austria
Tel +43 5242 66751 Fax +43 5242 66752

Brisbane, Australia
Tel +61 (0)7 3877 6333 Fax +61 (0)7 3343 8371

Singapore
Tel +65 6273 6362 Fax +65 6273 8161

Over 30 Offices Worldwide

www.heatandcontrol.com • info@heatandcontrol.com • ©2004 Heat and Control, Inc.