

HEAT AND CONTROL

®

HeatWave® Pellet Snack Fryer

Expand your snack business using the latest technology in continuous pellet snack fryers.



Patented oil curtain frying

HeatWave is the most advanced technology for continuous fry-popping of low capacities of pellet snacks. Instead of submerging pellets, HeatWave expands them with multiple curtains of oil, operating with a dramatically lower oil volume than conventional fryers.

Superior product quality

Oil curtains produce snacks with a superior texture. Rapid use of the low oil volume assures a fresh flavor.

Clean operation

Oil continuously passes through a strainer basket for large particle removal. Rugged stainless steel construction includes a lift-off hood for complete cleaning access.

Energy efficient

HeatWave's energy-efficient design is available with 220v or 440v electric heating.

Simple control

Oil temperature, frying time and oil pump operation are fully adjustable from an easy-to-use control panel, pre-wired and mounted on the fryer.

Optional equipment

- Canister filter with replaceable filter elements for continuous fines removal
- Seasoning applicators

HeatWave® Pellet Snack Fryer

Model HWF-E

Heat and Control supports you with the most efficient snack machinery and services.

As your business grows, Heat and Control can provide everything you need for efficient snack processing, inspection, and packaging.

- Continuous & batch fryers
- Oil heating & filtration
- Seasoning applicators
- Conveyors & product distribution systems
- CEIA metal detectors
- Ishida weighers, checkweighers & snack bagmakers
- Ishida flexible strip-pack bagmaker
- Parts & service
- Training
- Technical support

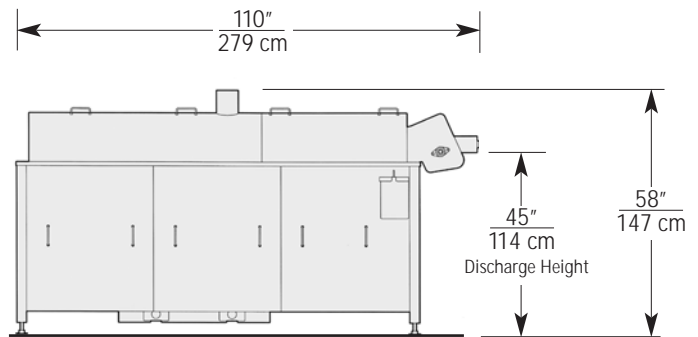
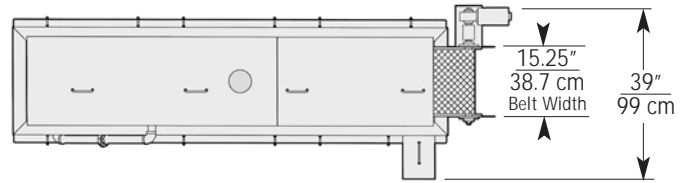

Pellet feeder required for optimal operation.

Dimensions are rounded to the nearest inch/centimeter.

Constant improvement and engineering innovations mean these specifications may change without notice.

HEAT AND CONTROL

®



Headquarters

21121 Cabot Blvd., Hayward, CA 94545 USA
Tel 1 800 227 5980 / 1 510 259 0500 Fax 1 510 259 0600

Campbellville, Canada

Tel 905 854 5650 Fax 905 854 5653

Guadalajara, Mexico

Tel +52 (33) 3689 1146 Fax +52 (33) 3689 2240

Livingston, Scotland

Tel +44 (0)1506 420420 Fax +44 (0)1506 403919

Brisbane, Australia

Tel +61 (0)7 3877 6333 Fax +61 (0)7 3343 8371

Singapore

Tel +65 6273 6362 Fax +65 6273 8161

Over 30 Offices Worldwide

www.heatandcontrol.com • info@heatandcontrol.com • ©2007 Heat and Control, Inc.