

HEAT AND CONTROL®

SureCoat® Drum Breeder

Continuously apply uniform coatings of pre-dust, breading or seasoning to poultry, meat, seafood and vegetable products.

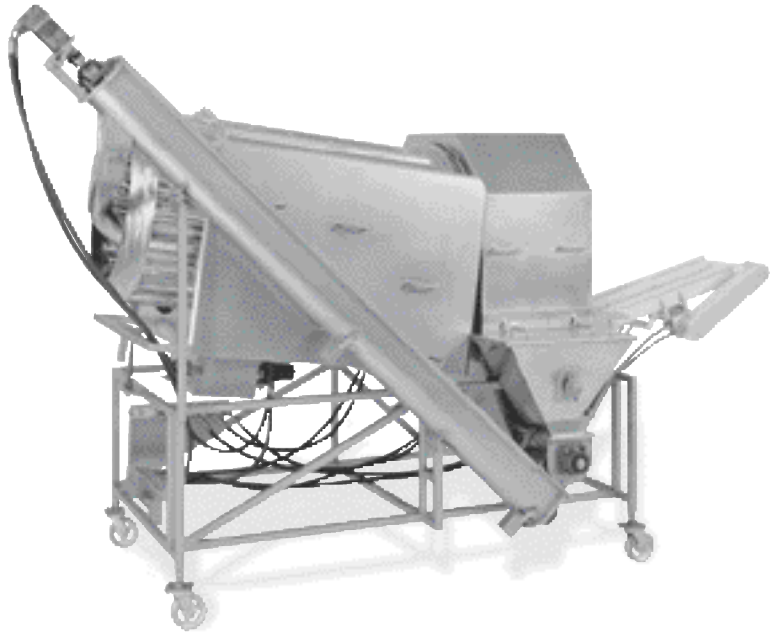
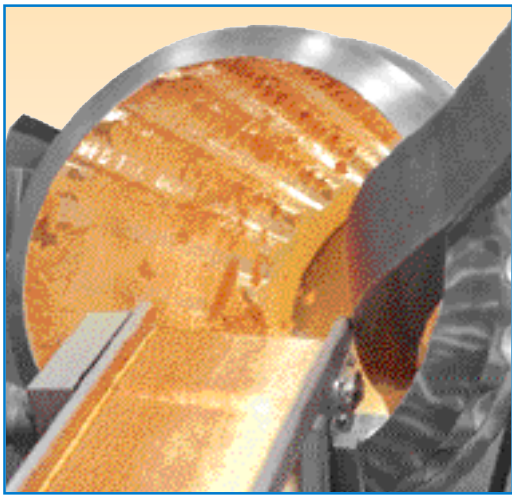

Pre-dust or bread up to 10,000 pounds per hour.

Simply revolutionary

No other coating applicator delivers the consistent, high-capacity coating and easy cleaning features of the patented SureCoat Drum Breeder.

Uniform coating

Flour, breading, or seasoning is thoroughly applied to all surfaces — *even inside skin folds and recesses* — as product is gently tumbled inside a slowly revolving drum. A metering hopper controls breading feed, while dough lumps are continuously removed as breading is recirculated.

Safe operation

Augers, drum and conveyor drives are fully shielded for operator safety.

Increase production

Choose models to coat 1,000 to 10,000 pounds per hour. Superior coating efficiency reduces reject rates to increase production profits. Recirculation of breading minimizes coating waste.

Quiet, reliable operation

Quiet Polychain® drum drive belts need no lubrication. Hydraulic drives provide reliable, variable speed operation of the coating drum, recirculation augers, belted discharge conveyor and optional feed conveyor.

Easy cleaning

Coatings can be quickly removed from the drum breeder, which is built to USDA specifications. The sloped drum and auger are fully accessible and minimize cleaning time.

SureSpread™ discharge

Optional SureSpread™ distributes coated product across the full width of conveyors feeding fryers, ovens, freezers or further coating equipment.



Improve the spread of product across your conveyor with SureSpread.™

SureCoat® Drum Breader | *Model DB*

Test the SureCoat Drum Breader and our complete line of processing and packaging systems at our Technical Center.

Models	DB-24	DB-36	DB-48
A	<u>145"</u>	<u>183"</u>	<u>190"</u>
Length	368cm	465cm	483cm
B	<u>101"</u>	<u>108"</u>	<u>110"</u>
Height	257cm	274cm	279cm
C*	<u>48" - 65"</u>	<u>49" - 65"</u>	<u>56" - 71"</u>
Infeed	122cm-165cm	124cm-165cm	142cm-180cm
D	<u>38" - 52"</u>	<u>38" - 56"</u>	<u>38" - 56"</u>
Discharge	97cm -132cm	97cm -142cm	97cm -142cm
Overall	<u>59"</u>	<u>68"</u>	<u>79"</u>
Width	150cm	173cm	201cm

Approximate reference dimensions are rounded to the nearest inch/centimeter. Dimensions vary with adjustment of casters, takeout & optional feed conveyors.

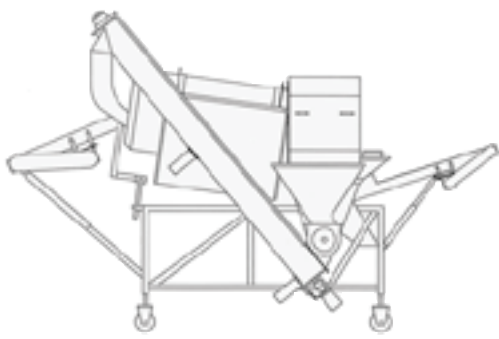

*Optional feed conveyor available to suit production line requirements.

Constant improvement and engineering innovations mean these specifications may change without notice.

