

## Crate Dumper Metering Hopper Vertical Screw Elevator

Rugged, reliable system empties crated product and meters a consistent flow to processing equipment.

### Crate Dumper

Safely tilts crates to empty potatoes, onions, and other produce into the Metering Hopper. Easily load up to 3,300 pound crates by forklift. The machine-mounted hydraulic tilt system controls product discharge rate. Tubular frame improves cleaning access.

### Metering Hopper

80 cubic feet storage capacity and your choice of belt or auger discharge for consistent delivery of product to the Vertical Screw Elevator. Sloped hopper walls and a shielded bottom prevent product damage and clogging. Adjust output with a variable speed mechanical drive. Tubular frame improves cleaning access.

### Vertical Screw Elevator

Large diameter variable speed auger quickly elevates your product to peelers or other equipment, while separating rocks and other debris. The auger's rugged bottom bearing provides long service and easy maintenance. Flanged vertical tube simplifies auger removal and includes water sprays. Door in tank facilitates cleaning.



1 *Crate Dumper*  
2 *Metering Hopper (belt discharge)*  
3 *Vertical Screw Elevator*

### Optional Accessories

- Adjustable crate size and product discharge cover for Crate Dumper.
- Non-powered belt cover for Crate Dumper gently meters delicate product while keeping liner bags in their boxes.
- Dust control hood for Metering Hopper.
- Automatic Rock Remover for Vertical Screw Elevator protects downstream equipment by continuously removing rocks and debris.
- Discharge chutes on Vertical Screw Elevator to feed one or more peelers.



Crate Dumper | Model CD

Metering Hopper | Model PMH

Vertical Screw Elevator | Model VSE

Choose epoxy-coated steel or stainless steel construction.  
Customized large-capacity systems are also available.

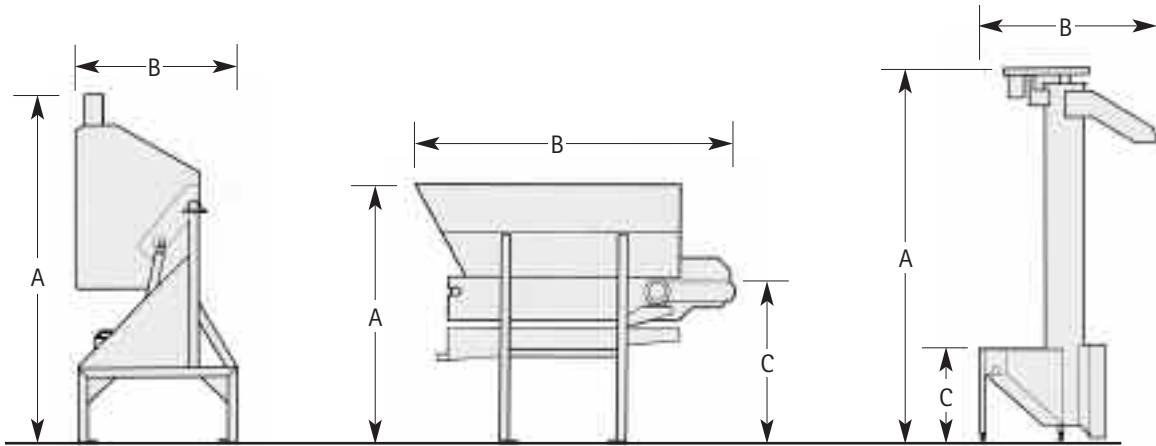

Crate Dumper		Metering Hopper		Vertical Screw Elevator	
A Height	115" / 292 cm	A Height	96" / 244 cm	A Height	144" / 366 cm
B Length	152" / 132 cm	B Length	109" / 277 cm	B Length	43" / 109 cm
Width	68" / 173 cm	C Discharge	56" / 142 cm	C Infeed	36" / 91 cm
		Width	60" / 152 cm	Width	45" / 114 cm

*Approximate dimensions are rounded to the nearest inch/centimeter. Equipment is available in special sizes to fit your production line.*

*Constant improvement and engineering innovations mean these specifications may change without notice.*

**HEAT AND CONTROL**

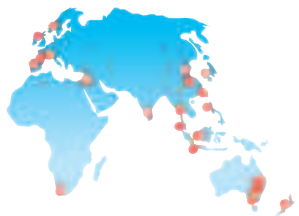

Headquarters  
21121 Cabot Blvd., Hayward, CA 94545 USA  
Tel 1 800 227 5980 / 1 510 259 0500 Fax 1 510 259 0600  
Guadalajara, Mexico  
Tel 52 33 3689 1146 Fax 52 33 3689 2240  
Livingston, Scotland  
Tel +44 (0)1506 420420 Fax +44 (0)1506 403919  
Schwaz-Vomperbach, Austria  
Tel +43 5242 66751 Fax +43 5242 66752  
Brisbane, Australia  
Tel +61 (0)7 3877 6333 Fax +61 (0)7 3343 8371  
Singapore  
Tel +65 6273 6362 Fax +65 6273 8161

Over 30 Offices Worldwide [www.heatandcontrol.com](http://www.heatandcontrol.com) • [info@heatandcontrol.com](mailto:info@heatandcontrol.com) • ©2004 Heat and Control, Inc.