

**HEAT AND CONTROL**

®

## FastBack® 260E™ Horizontal Motion Conveyor



*260E conveys heavier loads at faster transfer rates than any comparable conveyor.*

*260E shown with Revolution™ proportional discharge gate.*



**Faster, simpler, smoother and more powerful:  
260E conveys heavy loads and products others can't.**

### **Powerful conveying**

Move over 60,000 lbs/hr (28 tons/hr) without bogging down. High drive accelerations deliver the benefits of horizontal motion conveying for products that previously could only be handled by vibratory conveyors.

### **Patented drive**

FastBack's patented drive has proven it's reliability in hundreds of installations. No preventative maintenance is required. Easily replace drive and motor units without removing the pan or top cover.

### **Fastest travel rate**

Two times faster than other horizontal motion conveyors, 260E moves products at up to 40 ft/min (12meters/min).

### **Eliminate product breakage**

Gentle slow-forward fast-back motion safely conveys even the most delicate products with less breakage and coating loss than vibratory conveyors.

### **Quiet operation**

Low 70 dB operation with product complies with stringent government sound regulations.

### **Maintain pre-mixed blends**

Size separation is eliminated because product moves by sliding instead of bouncing.

### **Easy cleaning**

Coatings remain on products and do not build up in the conveyor pan. There are no hard-to-clean areas on the drive base.

### **Simple installation**

Pre-wired and plumbed, all electrical and pneumatic controls are mounted in the conveyor base for easy ready-to-run installation.



***One drive fits all!***

*Reduce spares. Use one drive base with different pan sizes to reduce costs of layout changes.*

# FastBack® Horizontal Motion Conveyor

Model 260E

Single side drive access allows closer conveyor spacing & convenient service of drive modules.

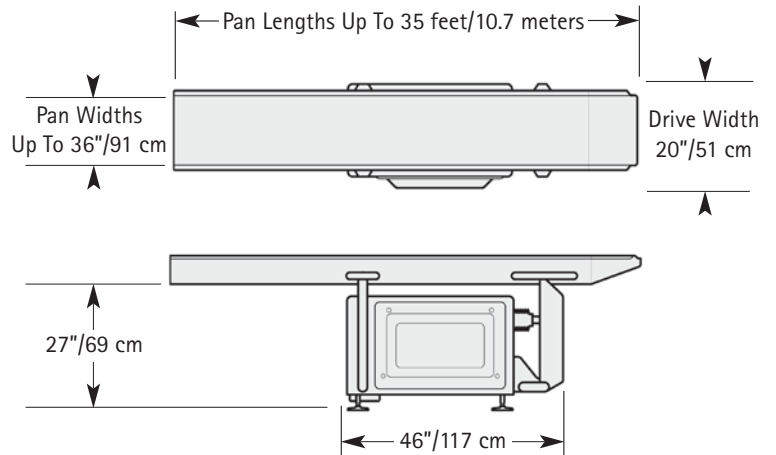
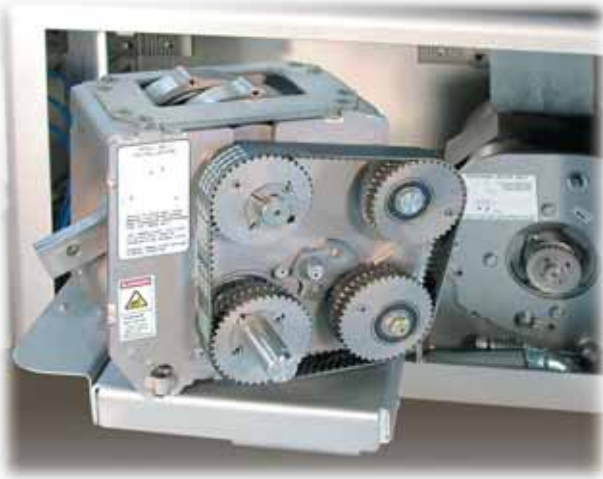

Quickly & easily remove the modular transmission and drive without removing the pan or top cover.

## Optional features

- Full washdown drive
- Revolution™ proportional discharge gate
- Special end and mid-gates
- Custom pan configurations
- Fines removal screen sections
- Rapid Deployment™ modular platforms

Custom pan sizes & configurations available.

*Dimensions are rounded to the nearest inch/foot & centimeter/meter.*

Constant improvement and engineering innovations mean these specifications may change without notice.

Protected by patents granted and pending.

**HEAT AND CONTROL**®



# FastBack®

Headquarters  
21121 Cabot Blvd., Hayward, CA 94545 USA  
Tel 1 800 227 5980 / 1 510 259 0500 Fax 1 510 259 0600

Campbellville, Canada  
Tel 905 854 5650 Fax 905 854 5653

Guadalajara, Mexico  
Tel +52 (33) 3689 1146 Fax +52 (33) 3689 2240

Livingston, Scotland  
Tel +44 (0)1506 420420 Fax +44 (0)1506 403919

Brisbane, Australia  
Tel +61 (0)7 3877 6333 Fax +61 (0)7 3343 8371

Singapore  
Tel +65 6273 6362 Fax +65 6273 8161

Over 30 Offices Worldwide [www.heatandcontrol.com](http://www.heatandcontrol.com) • [info@heatandcontrol.com](mailto:info@heatandcontrol.com) • ©2008 Heat and Control, Inc.