

**HEAT AND CONTROL**

®

## FastBack® 90E Distribution Conveyor



*Compact size and powerful drive make FastBack 90E ideal for weigher feeding and product distribution.*



**Cost-effective, compact, powerful horizontal motion conveyor maximizes product distribution efficiency.**

FastBack 90E combines a small and powerful drive with a wide variety of pan sizes to improve transfer and distribution for diverse applications.

FastBack speeds are programmable and automatically adjust to match product demands of multihead weighers. Instant stop-start optimizes product delivery.

Use the same 90E drive base with different pan sizes to reduce costs for spare parts and layout changes.

FastBack's slow-forward fast-back horizontal motion prevents product fractures, breakage and loss of seasonings and coatings. Valuable coatings remain on products and do not build up in the conveyor pan. 70dB operation with most products provides a quieter working environment.

Pre-wired with all photoeyes and electrical controls integrated into its base, FastBack 90E is ready-to-run for simple installation.

- No pan cracking, flexure tuning
- No preventative maintenance
- Reduce product breakage and coating loss
- Maintain pre-mixed blends
- Increase access to weigher
- Cut cleaning costs
- Programmable speed
- Instant stop/start
- Dry or USDA washdown models

# FastBack® Distribution Conveyor

Model 90E

FastBack provides the cleanest, most efficient product distribution for dry and frozen foods.

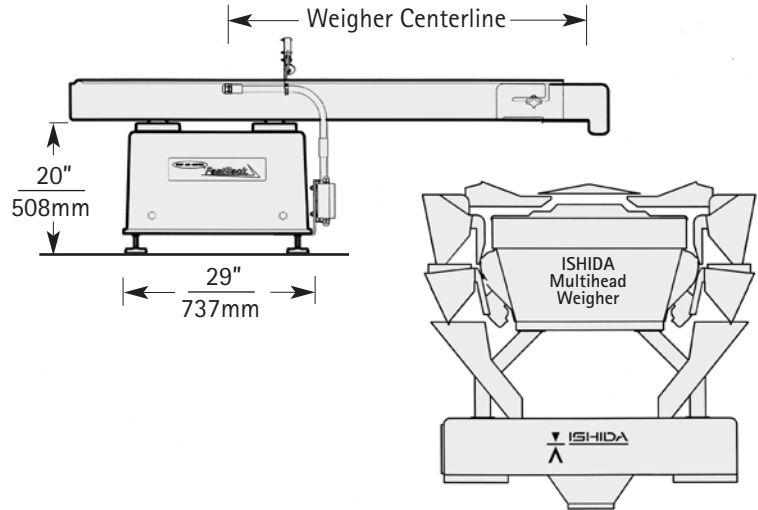

Gentle FastBack conveying prevents the loss and build-up of valuable seasonings and coatings, eliminating unscheduled downtime for pan cleaning.

### Weigher Centerline

### Product Transfer Rate

6.56 ft. / 2.00 M	Up to 1,550 ft <sup>3</sup> /hr / 44 M <sup>3</sup> /hr
8.00 ft. / 2.44 M	Up to 1,280 ft <sup>3</sup> /hr / 36 M <sup>3</sup> /hr
8.50 ft. / 2.60 M	Up to 1,025 ft <sup>3</sup> /hr / 29 M <sup>3</sup> /hr
9.00 ft. / 2.75 M	Up to 1,025 ft <sup>3</sup> /hr / 29 M <sup>3</sup> /hr
9.80 ft. / 3.00 M	Up to 800 ft <sup>3</sup> /hr / 22 M <sup>3</sup> /hr Recommended for twin-tube packaging

*Dimensions are rounded to the nearest inch/millimeter or foot/meter. Constant improvement and engineering innovations mean these specifications may change without notice.*

**HEAT AND CONTROL**

®



Headquarters  
21121 Cabot Blvd., Hayward, CA 94545 USA  
Tel 1 800 227 5980 / 1 510 259 0500 Fax 1 510 259 0600

Campbellville, Canada  
Tel 905 854 5650 Fax 905 854 5653

Guadalajara, Mexico  
Tel +52 (33) 3689 1146 Fax +52 (33) 3689 2240

Livingston, Scotland  
Tel +44 (0)1506 420420 Fax +44 (0)1506 403919

Brisbane, Australia  
Tel +61 (0)7 3877 6333 Fax +61 (0)7 3343 8371

Nanjing, People's Republic of China  
Tel +86 257 8403 5000 Fax +86 257 8580 5033

Singapore  
Tel +65 6273 6362 Fax +65 6273 8161

Over 30 Offices Worldwide

[www.heatandcontrol.com](http://www.heatandcontrol.com) • [info@heatandcontrol.com](mailto:info@heatandcontrol.com) • ©2008 Heat and Control, Inc.