

Potato Chip Fryer



◀ 4,200 finished lb/hr
Multi-Zone Fryer
with KleenSweep,
centrifugal oil filter.

Compact modular
fryer produces
400 lbs/hr of
finished chips. ▼

With hundreds of installations worldwide, our fryers deliver superior product quality, clean operation & total reliability.

Precise frying control

- Continuous oil circulation between the fryer, filter and heat exchanger provides precise control of temperature and rapid adjustment to product load changes.
- Specially engineered oil inlet maintains positive oil flow to clear the product infeed area without back eddies or undercurrents.
- Fryer metering paddles and a submerger conveyor control cook times for consistently uniform product.

Superior oil quality

Low oil volume and rapid oil turnover assure fresh product with a long shelf life. Optimal oil level is automatically maintained.

Continuous filtration

Circulating oil keeps fines in suspension for efficient removal. Every minute, 100% of the system oil volume passes through a filter to remove product particles for the highest oil and product quality.

400 to 6,500 lbs/hr

Standard fryers are available for 400 to over 6,500 lbs/hr of finished potato chips. Batch, multi-zone, and fabricated chip fryers are also available for a variety of capacities.



Easy cleaning

Cleaning solution follows the same path as oil for thorough sanitation. Clean-in-place spray nozzles in the hood and exhaust stack clean all areas above the oil path. Self-locking motorized screw jacks raise the hood and paddle/submerger conveyor clear of the pan for complete cleaning access.

Potato Chip Fryer | Model PC

Multi-zone frying control

Our Multi-Zone Fryers deliver the ultimate in processing flexibility. Create custom temperature profiles to produce traditional, ultralight or kettle style chips all from the same fryer.

Oil is introduced and removed at different points along the fryer pan for precise control of temperature, product flow and fines removal. Fry at lower temperatures to produce lighter color chips. All chips receive the same exposure to oil for uniform cooking.

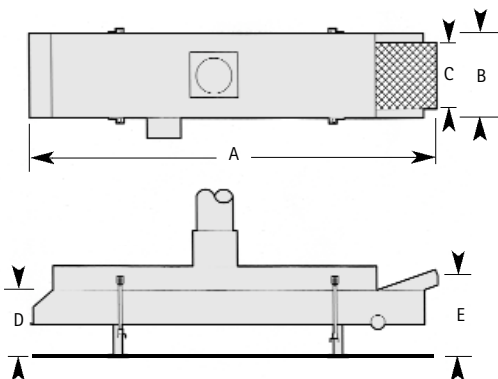

Model	Finished lbs/hr	A Length	B Width	C Belt Width	D Feed Height	E Disch. Height
PC 4	400	26' / 7.9m	51" / 130cm	20" / 51cm	47" / 119cm	40" / 102cm
PC 10	1,000	27' / 8.2m	64" / 163cm	36" / 91cm	45" / 114cm	40" / 102cm
PC 14	1,400	31' / 9.5m	73" / 186cm	46" / 117cm	48" / 122cm	36" / 91cm
PC 21	2,100	34' / 10.4m	88" / 224cm	60" / 152cm	48" / 122cm	36" / 91cm
PC 32	3,200	40' / 12.2m	94" / 239cm	66" / 168cm	50" / 127cm	38" / 97cm
PC 42	4,200	43' / 13.1m	109" / 277cm	78" / 198cm	52" / 132cm	40" / 102cm
PC 50	5,000	47' / 14.3m	109" / 277cm	78" / 198cm	52" / 132cm	40" / 102cm

Dimensions are rounded to the nearest inch/foot and centimeter/meter.

Constant improvement and engineering innovations mean these specifications may change without notice.



HEAT AND CONTROL

®



Over 30 Offices Worldwide

Headquarters
 21121 Cabot Blvd., Hayward, CA 94545 USA
 Tel 1 800 227 5980 / 1 510 259 0500 Fax 1 510 259 0600
 Guadalajara, Mexico
 Tel 52 33 3689 1146 Fax 52 33 3689 2240
 Livingston, Scotland
 Tel +44 (0)1506 420420 Fax +44 (0)1506 403919
 Schwaz-Vomperbach, Austria
 Tel +43 5242 66751 Fax +43 5242 66752
 Brisbane, Australia
 Tel +61 (0)7 3877 6333 Fax +61 (0)7 3343 8371
 Singapore
 Tel +65 6273 6362 Fax +65 6273 8161

www.heatandcontrol.com • info@heatandcontrol.com • ©2004 Heat and Control, Inc.