

VersaPeel® Batch Peeler | Model VP

VersaPeel® delivers superior peeling control and simple, reliable performance.

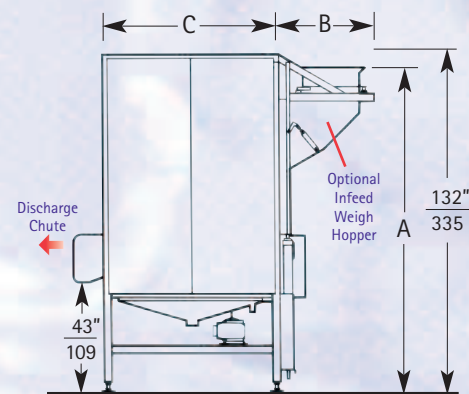

Abrasive liners and the rotary disc can be easily replaced.



Models	VP36	VP48
Diameter	36"	48"
Peeling Drums	91	122
A	145"	127"
Infeed Height	368	323
B	32"	37"
Infeed Length	81	94
C	57"	69"
Peeler Length	145	175
Peeler Width	61"	73"
	155	185

Dimensions shown for optional infeed weigh hopper. All dimensions are rounded to the nearest inch/centimeter.

Constant improvement and engineering innovations mean these specifications may change without notice.



We also build continuous peelers, single and two-stage batch peelers, plus complete produce unloading, transfer, sizing, storage, processing and packaging systems.



HEAT AND CONTROL



Headquarters
21121 Cabot Blvd., Hayward, CA 94545 USA
Tel 1 800 227 5980 / 1 510 259 0500 Fax 1 510 259 0600

Guadalajara, Mexico
Tel 52 33 3689 1146 Fax 52 33 3689 2240

Livingston, Scotland
Tel +44 (0)1506 420420 Fax +44 (0)1506 403919

Schwaz-Vomperbach, Austria
Tel +43 5242 66751 Fax +43 5242 66752

Brisbane, Australia
Tel +61 (0)7 3877 6333 Fax +61 (0)7 3343 8371

Singapore
Tel +65 6273 6362 Fax +65 6273 8161

Over 30 Offices Worldwide www.heatandcontrol.com • info@heatandcontrol.com • ©2003 Heat and Control, Inc.

HEAT AND CONTROL

VersaPeel® Batch Peeler



- 0.5% - 3% peel loss
- Reduce potato costs
- Increase production
- Cleaner line operation

HEAT AND CONTROL®

VersaPeel® Batch Peeler

Drastically reduce your potato costs... or get thousands of extra pounds of chips without using more potatoes!

By reducing peel loss to under 0.5% on fresh potatoes and 3% on long term storage potatoes, the patented VersaPeel three-stage batch peeler can pay for itself in one year or less.

With VersaPeel, you'll use fewer potatoes to meet your current production goals, or produce thousands of extra pounds of chips without using more potatoes!

Peeled potatoes have a smooth surface and retain their original shape. This greatly improves slicer yield and minimizes scrap generation, so the cost of cleaning your entire line is also reduced.

VersaPeel progressively peels and polishes potatoes, rapidly removing peel – even from eyes and recesses. Product never "short circuits" or bounces to escape peeling, and flat spots are virtually eliminated.

A unique rotary abrasive disc at the base of the drums tumbles product for consistent peel removal.

Automatic loading and unloading increases production efficiency. An optional weigh-in weigh-out feature lets you precisely monitor the yield of each batch.

For maximum peeling control, dwell times and the abrasive liners in each drum can be changed to suit specific potato characteristics.

VersaPeel®

- 0.5% to 3% peel loss
- Delivers smooth, natural shaped potatoes
- Improves slicer efficiency
- Cleaner line operation

Get More Chips From Your Potatoes!

VersaPeel can deliver thousands of pounds of additional product each year from the same amount of potatoes you are now using. Compare VersaPeel's savings at 3% vs. 8% peel loss operating for one 8-hour shift per day, 5 days a week for 50 weeks, with a potato cost of 9 cents per pound:

Additional product with no added cost for potatoes	Potato savings or from reduced peel loss
1,000 lbs/hr	
112,380 lbs/yr	or \$31,860/yr
2,100 lbs/hr	
235,998 lbs/yr	or \$66,906/yr
4,200 lbs/hr	
471,996 lbs/yr	or \$133,812/yr

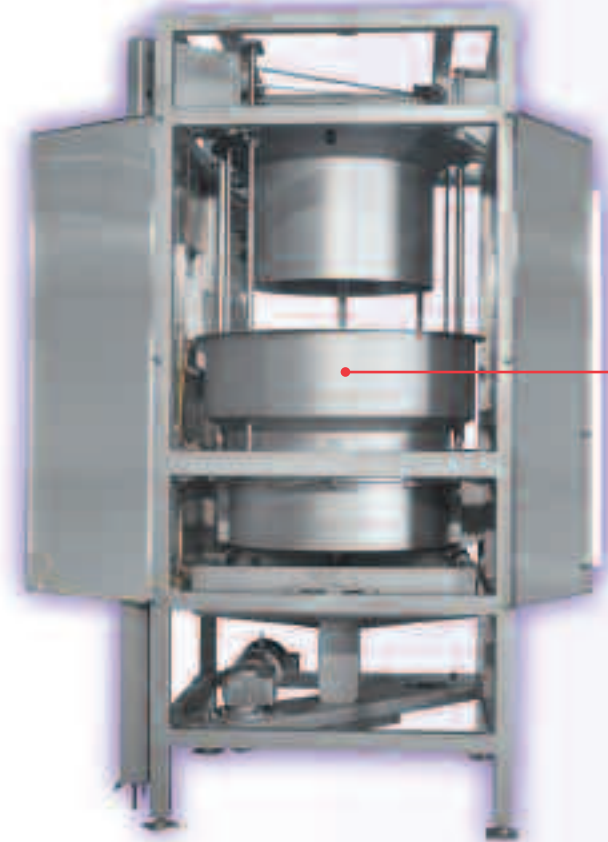

Doors on both sides provide easy access to abrasive drums, disc and drive system. Two drive bearings are lubricated via external fittings.



Progressive Peeling

Stage 1

As potatoes enter Drum 1, the rotary disc slows to prevent product damage. When the disc accelerates to the pre-set peeling speed, product is tumbled against the coarse abrasive or brush drum liner to quickly break the skin. For maximum throughput, the feed hopper is pre-filled before each peeling cycle ends.

Stage 2

Drum 1 raises, exposing product to less abrasive brushes in Drum 2.

Stage 3

Drum 2 raises, exposing potatoes to fine brushes in Drum 3 which polish surfaces and recesses. The rotary disc slows and Drum 3 raises, gently discharging potatoes through a tangential outlet.

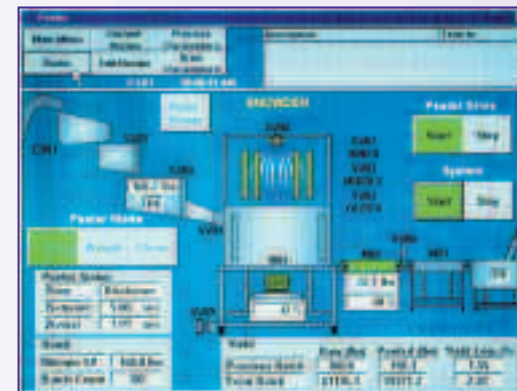

Easily program different peeling characteristics into VersaPeel's optional control system.

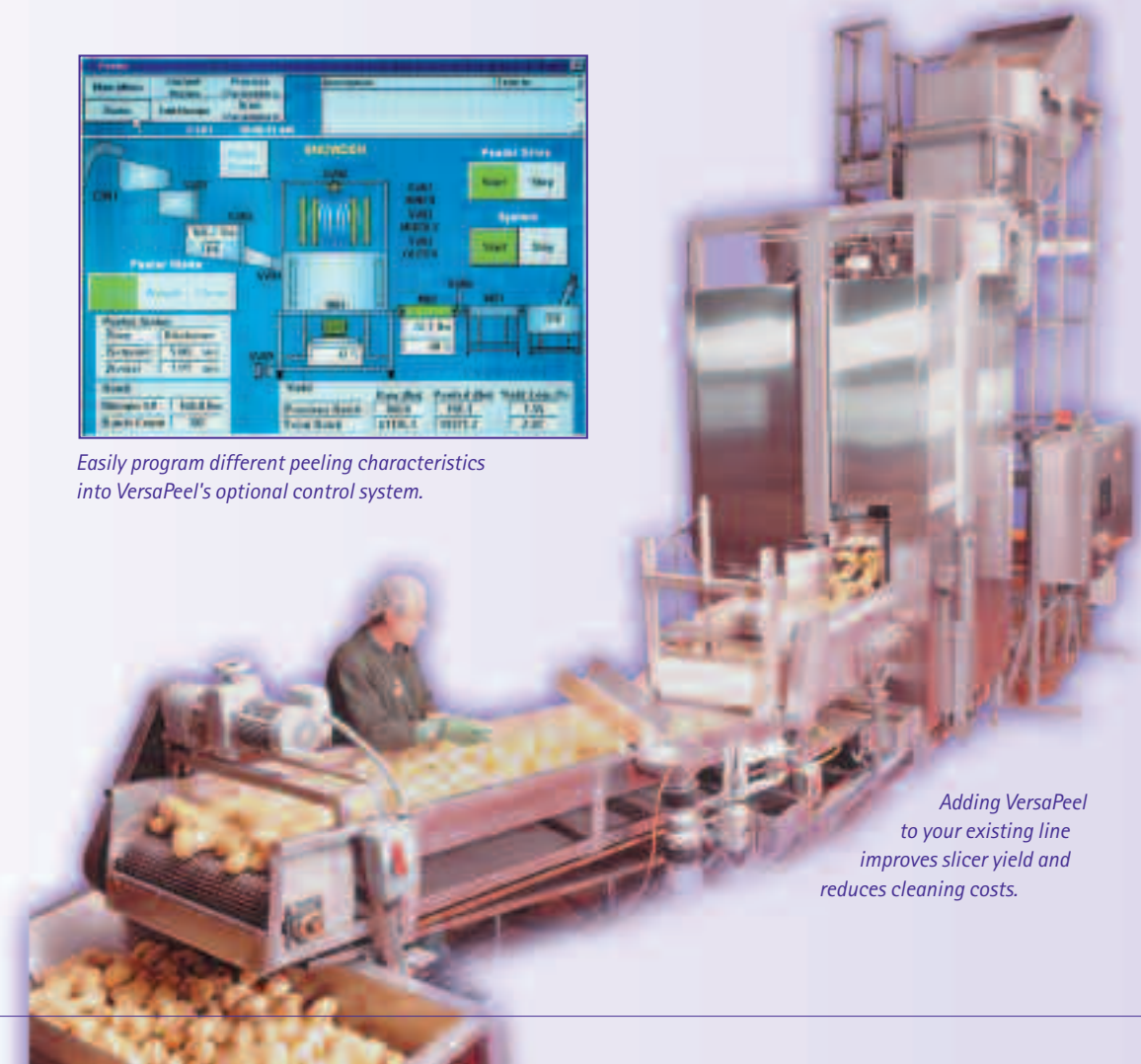

Adding VersaPeel to your existing line improves slicer yield and reduces cleaning costs.