

HEAT AND CONTROL

Oil Roaster continuous nut fryer

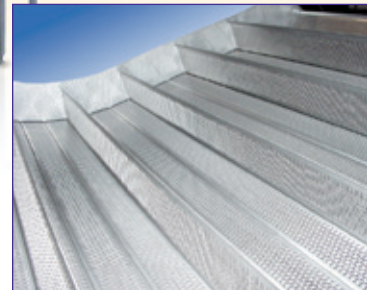

Conveyor belt flights meter product for consistent roasting.

Specially designed for low oil volume, precise temperature control and clean operation, this is the ideal roaster for all varieties of nut meats.

Continuous roasting control

Heat and Control's unique continuous fryer design gives you total control of product quality.

- Continuous oil circulation between the fryer, filter and heat exchanger maintains a consistent roasting temperature and rapidly adjusts to changes in product load.
- Oil circulates at high velocity through multiple inlets to penetrate the product pack for uniform roasting, fast oil turnover, and high capacity.

Superior oil quality

Low system oil volume and rapid oil turnover assure fresh product with a long shelf life. Operating oil level is automatically maintained.

Continuous filtration

Circulating oil keeps fines in suspension for efficient removal. Each minute, 100% of the system oil volume passes through a Drum Pre-Filter for optimal oil quality.

Low oil volume

Outside return conveyor belt in a shallow, flat-bottom pan minimizes oil volume.

Easy cleaning

Cleaning solution circulates through the same areas as cooking oil for thorough sanitation. Clean-in-place spray nozzles in the hood and exhaust stack clean all areas above the oil path. Self-locking motorized screw jacks raise the hood and conveyor clear of the pan for complete access.

Optional equipment

- Honey-coated nut fryers with inside-return belts
- Custom conveyor designs for any nut variety
- Primary and secondary oil filters
- Pollution control heat exchanger
- Oil Mist Eliminator for fryer exhaust
- Exhaust heat recovery system

Oil Roaster continuous nut fryer | Model OR

We've got a processing and packaging system for every type of nut you process: Peanuts, almonds, sunflower meats, cashews, honey-roasted, and more!

Standard fryer features include:

- Small capacity direct-heated continuous and batch fryers
- Blanchers
- Nut feeders
- Coolers
- Glazers
- Salt and seasoning application systems
- Spray Dynamics coating applicators
- Product blending systems
- Conveyors and distribution systems
- CEIA metal detectors
- Ishida multihead weighers and checkweighers
- Ishida snack bagmakers
- Control systems



For the lowest of all volume and greatest versatility, ask about our patented HeatWave[®] oil curtain fryer!

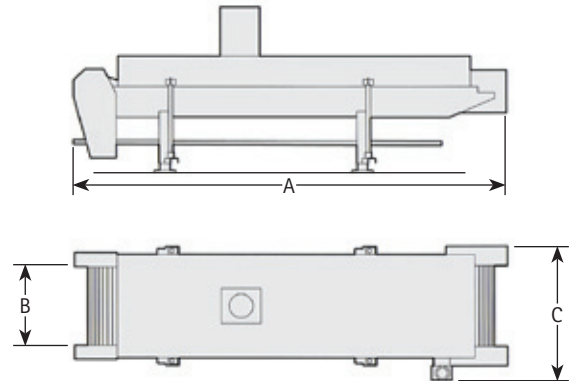

Standard Models

	A	B	C
Model	Overall Length	Belt Width	Overall Width
NC-3006	199" / 5.0m	30" / 76cm	68" / 173cm
NC-3610	247" / 6.2m	36" / 91cm	74" / 188cm
NC-4812	271" / 6.8m	48" / 123cm	86" / 218cm
NC-5414	295" / 7.4m	54" / 137cm	92" / 234cm

Dimensions are rounded to the nearest inch / millimeter.

Additional sizes are available to fit your line.

Constant improvement and engineering innovations mean these specifications may change without notice.

HEAT AND CONTROL®

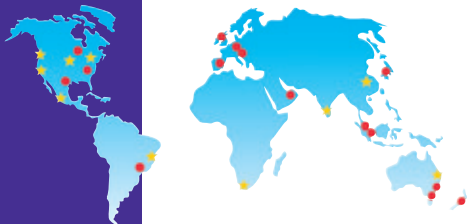

Headquarters
21121 Cabot Blvd., Hayward, CA 94545 USA
Tel 1 800 227 5980 / 1 510 259 0500 Fax 1 510 259 0600

Cambridge, Canada
Tel 519 623 1100 Fax 519 623 1052

Guadalajara, Mexico
Tel +52 (33) 3689 1146 Fax +52 (33) 3689 2240

Livingston, Scotland
Tel +44 (0)1506 420420 Fax +44 (0)1506 403919

Brisbane, Australia
Tel +61 (0)7 3877 6333 Fax +61 (0)7 3343 8371

Nanjing, People's Republic of China
Tel +86 25 8403 5000 Fax +86 25 8580 5033

Singapore
Tel +65 6844 6853 Fax +65 6841 2359

Over 30 Offices Worldwide

www.heatandcontrol.com • info@heatandcontrol.com • ©2012 Heat and Control, Inc.